

Linear Displacement Sensors LINEAR GAGE



LINEAR GAGE



Mitutoyo Precision Gage Heads

Full Lineup of Gage Heads from Ultra-high Precision to Excellent Cost-performance Types

Measurement principle

Optical transmission-type linear encoders

The gage heads mainly use optical transmission-type linear encoders, the principle of which is shown below. In this type, the light source (LED) and the detector element (photodiode) face each other with the main scale and index scale (20 μm pitch) positioned between them. As the scale moves with respect to the detector, the intensity of the light passing through the window in the index scale varies constantly. At this time, two synchronized sine-wave signals having a relative 90-degree phase difference are output.



These signals are then amplified and split electrically (with additional waveforms inserted) and output as 0.1 μm , 0.5 μm or 1 μm square-wave signals.

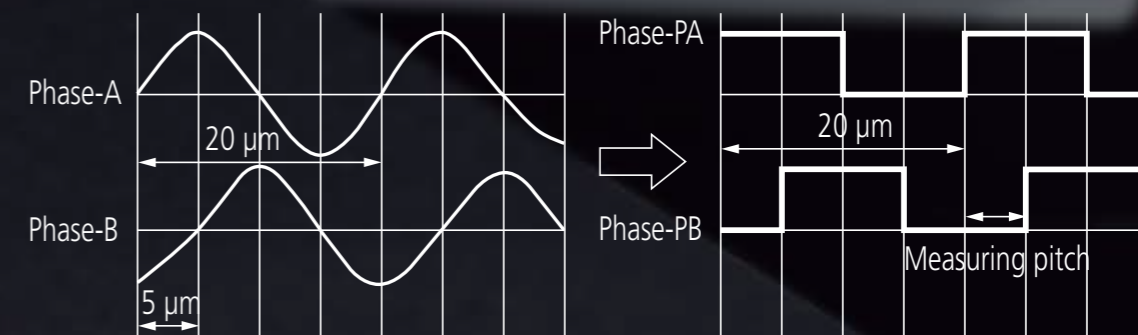
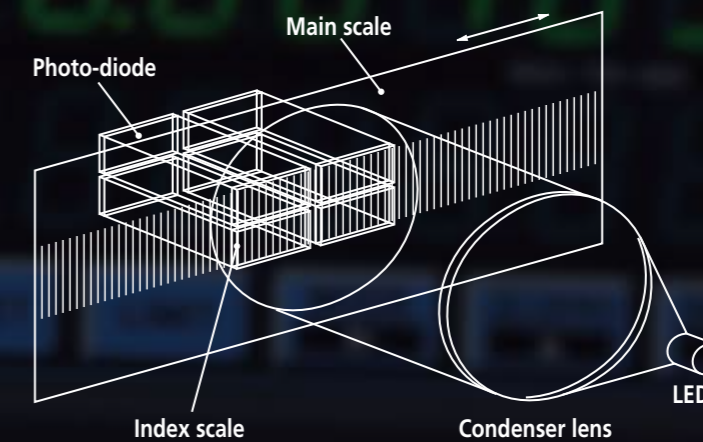

Traceability of Mitutoyo Standards

As of July, 2021

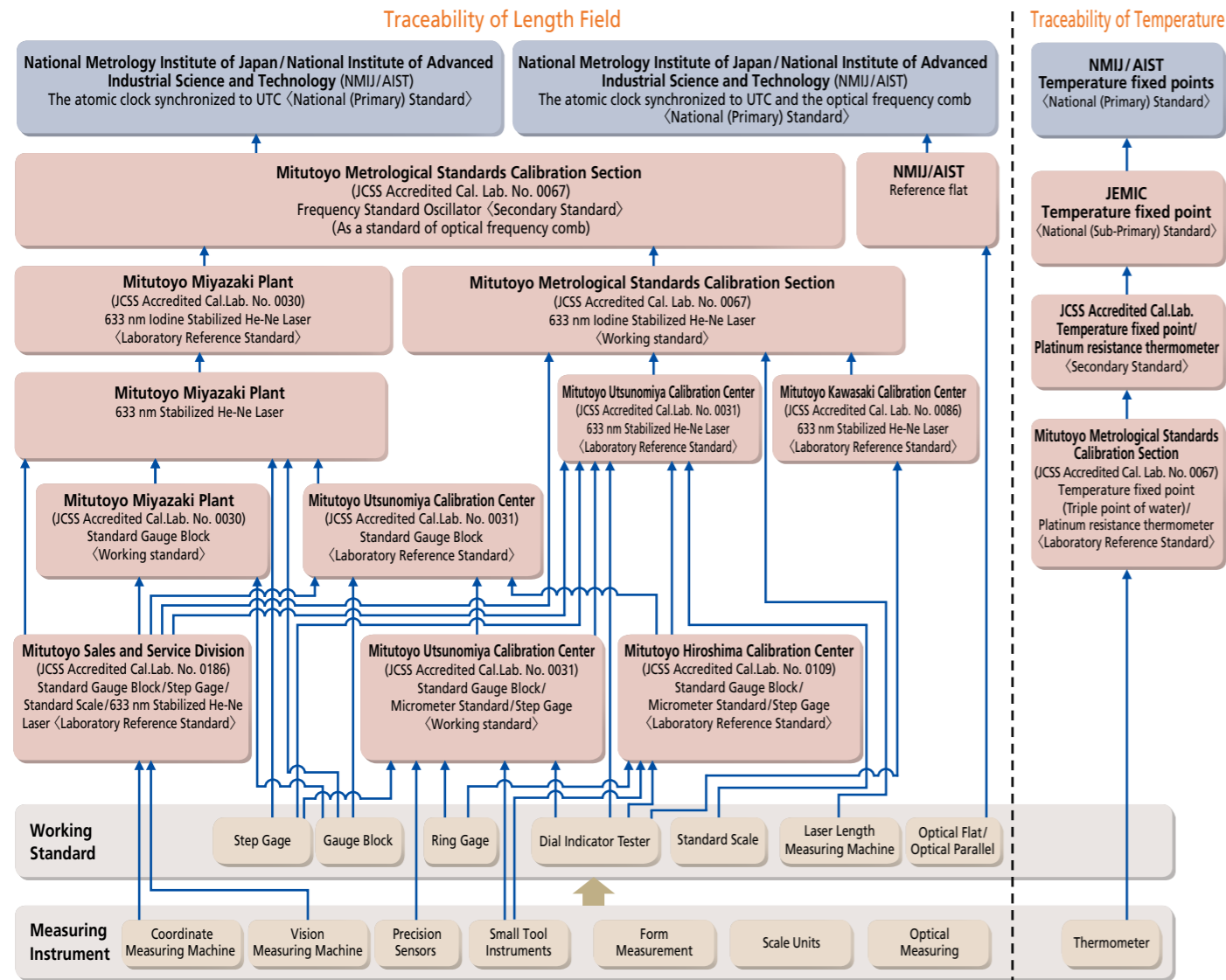

Note: This chart shows a simplified traceability system of Mitutoyo. Detailed traceability charts are published for each product.

I N D E X

Measurement principle	3
Traceability of Mitutoyo Standards	4
Applications	6 - 9
Gage Heads/Display units	10, 11
Gage Heads Specifications	
LG100	12 - 14
LG200	15
LGH	16, 17
LGS-1012P	18
Head Specifications (Optional accessories)	19 - 23
Head Specifications (Differential square-wave)	24
Head Specifications (Digimatic code)	25
Counter Specifications	
EJ-102N Counter, Interface Unit	26, 27
EC Counter - Only for Digimatic output	29
EH Counter - Panel mount, Multi-function Type with RS-232C	30 - 35
Communication Functions	
Origin Point Mark Detection	36
Connecting linear gages to counters / Comparative table of counter functions	37
Linear Gage Accessories (Optional)	39, 40
Quick Guide to Precision Measuring Instruments	
Quick Guide to Precision Measuring Instruments	41
Before using the gage head	42
Precautions in mounting a Linear gage	42 - 43



About CAD data provided from website

If required, customers can download 2D/3D CAD data for Mitutoyo measurement equipment from the Mitutoyo website for the purpose of using in customers' design work.

- Mitutoyo website

<https://www.mitutoyo.co.jp/eng/>

Applications

Precision Parts Manufacturing

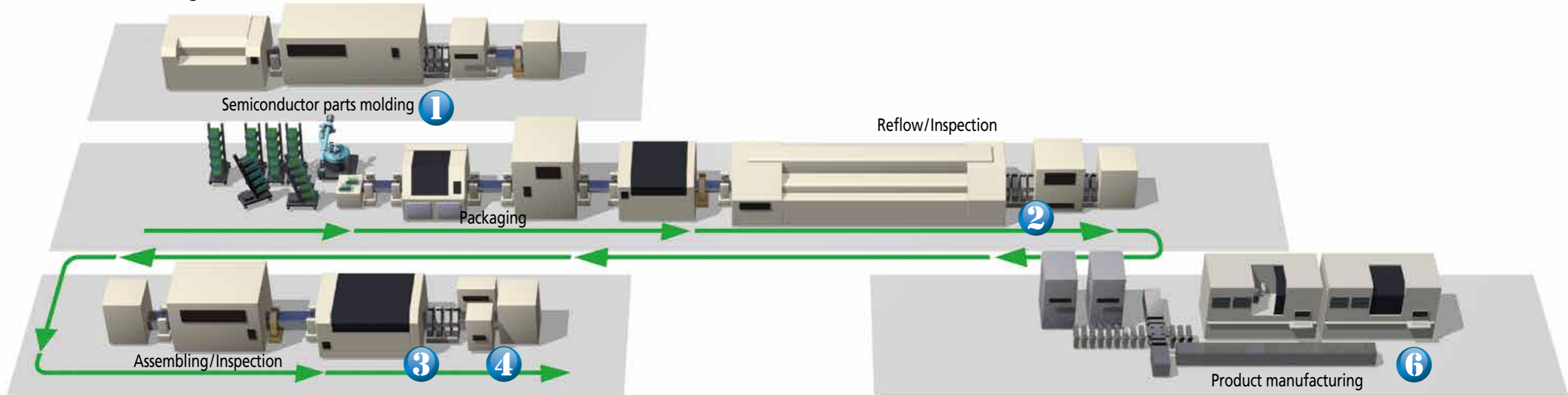

1 Roll gap measurement



2 PCB thickness measurement

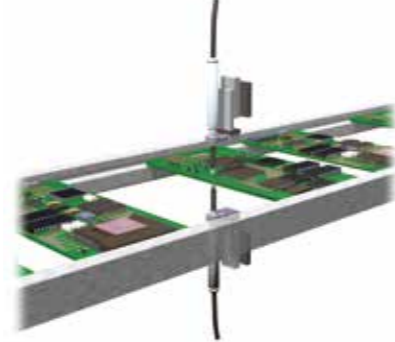

3 Chip parallelism measurement

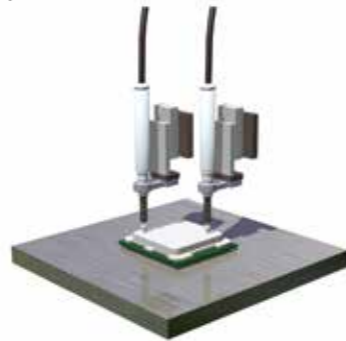

4 Seating check



5 Measurement of crimping height



6 FPD board multipoint measurement



7 Parallelism measurement of copying machine parts



Applications

Automobile Manufacturing Process

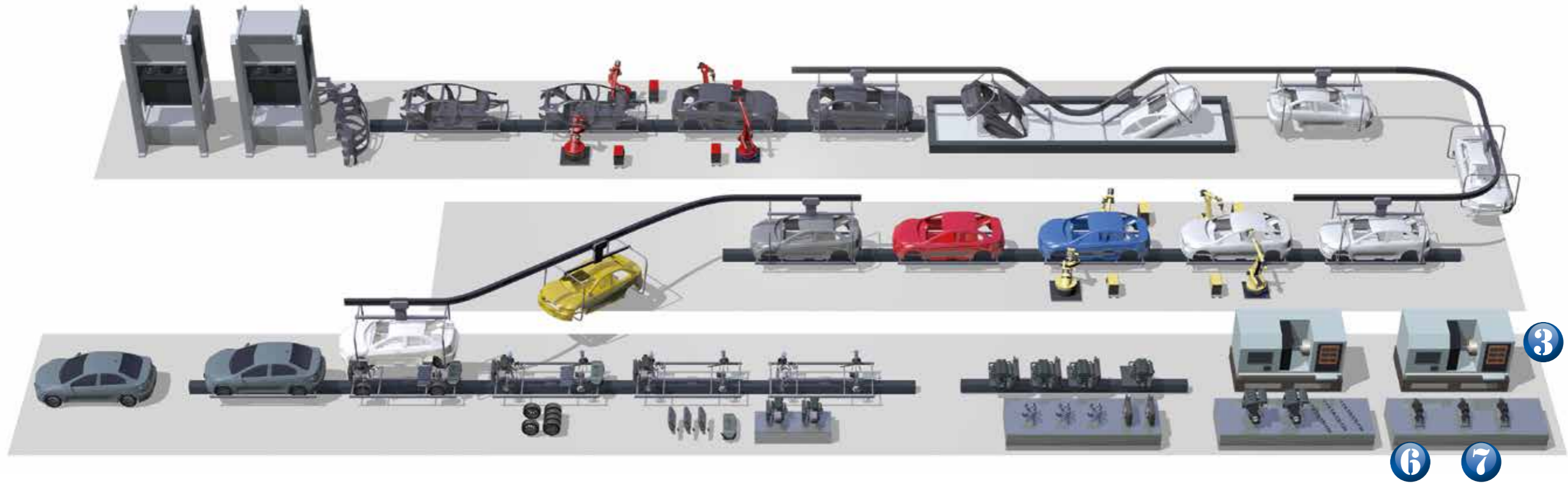

1 Cam-lift measurement



2 Brake disk multipoint measurement



3 Machine device tool length measurement



4 Workpiece discrimination

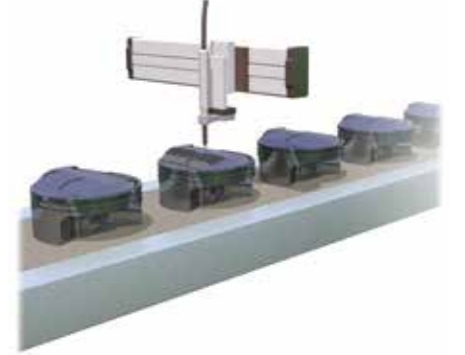

5 Flatness measurement



6 Workpiece height detection

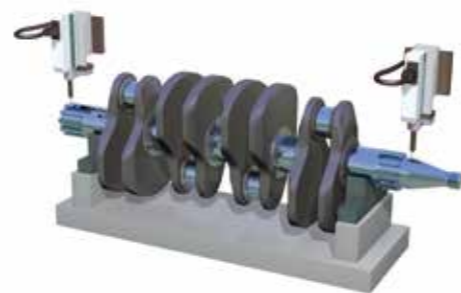

7 Workpiece runout measurement



8 Inspection fixture



Gage Heads/Display units

[Gage Heads]

Environment-Resistant

LG100

 Measuring range: 10 mm/25 mm/50 mm
 Resolution: 1 μm/0.5 μm/0.1 μm
 Refer to page 12



Slim Type



LG200*

 Measuring range: 10 mm
 Resolution: 1 μm/0.5 μm/0.1 μm
 Refer to page 15



*Function of reference point detection on counter is disabled

Digimatic output Type

LGS

 Measuring range: 12.7 mm
 Resolution: 10 μm
 Refer to page 18



High-accuracy Type

LGH
 Measuring range: 10 mm
 Resolution: 0.01 μm/0.005 μm
 Refer to page 16



[Conversion plug]

Conversion plug
21HZA196

Conversion plug
21HZA195

[Display units]

DIN rail-mounted Type

EJ-102N

 2-axis input, subtraction calculations
 8 units can be connected
 Refer to page 26



Panel mount

EH-102Z

 2-axis input, subtraction calculations
 Multi-function
 Refer to page 30



EH-101P (1 axis)
EH-102P (2 axes)

 Multi-function
 Refer to page 30



EH-102D

 2-axis input, subtraction calculations
 Multi-function
 Refer to page 30



Compact display Unit

EC-101D

 1-axis input
 Refer to page 29



[Interface Unit/Software]

Interface Unit

CC-Link 21HZA186
 Refer to page 26



PROFINET 21HZA187
 Refer to page 26



EtherNet/IP 21HZA188
 Refer to page 26



EtherCAT 21HZA264
 Refer to page 26



USB 21HZA149
 Refer to page 26



Setup tool for EJ counters

LG QuickSetupTool
 (can be downloaded for free from the Mitutoyo website)
 Refer to page 28



Measurement data acquisition software

SENSORPAK
 Refer to page 38

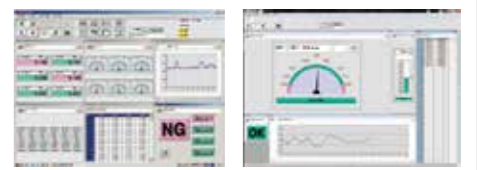



See video from here

- High-accuracy gage head suitable for in-line and in-laboratory use.
- Assures the expected repeatability (2σ) in the full measurement range and the narrow-range precision.
- Protection grade IP67G with sliding durability of 50 million times and more*1 and adoption of highly oil-resistant materials.
*1 10 mm range models (Actual value from in-house tests)
- All models have the origin point signal output function to restore the origin point position after recovery from problems such as overspeed.
- It can be connected to a compact counter (EJ counter) suitable for in-line use or building into a device or a multifunctional counter (EH counter)*2 suitable for use in measurement rooms.
*2 A conversion plug is required.

542-190 / 542-191 / 542-192

542-193 / 542-194 / 542-195

542-196 / 542-197

IP67 G

IP67 G

IP67 G

542-190

542-193

542-196

SPECIFICATIONS

Order No.	542-190	542-191	542-192	542-193	542-194	542-195	542-196	542-197	
Measuring range	10 mm			25 mm			50 mm		
Resolution	1 μm	0.5 μm	0.1 μm	1 μm	0.5 μm	0.1 μm	1 μm	0.5 μm	
Measuring accuracy (20 °C) L=arbitrary measuring length (mm)	1.5 + L/50 μm		0.8 + L/50 μm	1.5 + L/50 μm		0.8 + L/50 μm	1.5 + L/50 μm		
Small range accuracy	0.5 μm (Arbitrary 20 μm range)								
Repeatability: 2σ (20 °C)	0.3 μm								
Reference mark repeatability: σ (20 °C)	σ≈0.5 μm (at a constant reference point passing speed less than 300 mm/s in the same direction)								
Measuring force	Contact point downwards	1.4 N or less			4.6 N or less			5.7 N or less	
	Contact point horizontal	1.3 N or less			4.3 N or less			5.3 N or less	
	Contact point upwards	1.2 N or less			4.0 N or less			4.9 N or less	
Position detection method	Optical transmission-type Linear encoder								
Maximum response speed	1,500 mm/s	400 mm/s	1,500 mm/s	400 mm/s	1,500 mm/s	400 mm/s	1,500 mm/s	1,500 mm/s	
Output signal	90° phase difference, differential square wave (RS-422A equivalent)								
Minimum edge intervals	500 ns (2 MHz)	250 ns (4 MHz)		500 ns (2 MHz)	250 ns (4 MHz)		500 ns (2 MHz)	250 ns (4 MHz)	
Output signal pitch	4 μm	2 μm	0.4 μm	4 μm	2 μm	0.4 μm	4 μm	2 μm	
Reference mark position (Phase-Z)	Approx. 3 mm from contact point tip (lowest rest point)			Approx. 5 mm from contact point tip (lowest rest point)					
Mass	Approx. 260 g			Approx. 300 g			Approx. 400 g		
Contact point	ø3 mm carbide tipped (fixing screw: M2.5 (P=0.45) ×5), standard contact point: 901312								
Stem	ø8 mm			ø15 mm					
Bearing	Linear ball type								
Output cable length	2 m (directly from casing)								
Connector	Plug: HR10A-10P-10P (HIROSE), Compatible receptacle: HR10A-10R-10S (HIROSE), Compatible connector: HR10A-10J-10S (HIROSE)								
Operating temperature (humidity) ranges	0 to 50 °C (RH 20 to 80%, non-condensing)								
Storage temperature (humidity) ranges	-10 to 60 °C (RH 20 to 80%, non-condensing)								
Standard accessories	Wrench for contact point: 538610			Wrench for contact point: 210187					

Connector

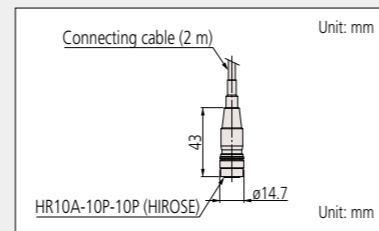

Optional Accessories

- Air lifter
For 10 mm range models: **02ADE230**
For 25 mm range models: **02ADE250**
For 50 mm range models: **02ADE270**
Note 1: Required air pressure: 0.2 to 0.4 MPa (With a 0.1 μm resolution type: 0.2 MPa)
Note 2: Spindle extends when air is supplied.



- Rubber boot (spare)
For 10 mm range models: **21HAA331**
For 25 mm range models: **21HZA176**
For 50 mm range models: **21HZA184**
Note 3: Dimensions are shown in the external dimensions drawing of the product.
- Thrust stem set:
For 10 mm range models: **02ADB680** (Thrust stem: **02ADB681**, Clamp nut: **02ADB682**)
For 25/50 mm range models: **02ADN370** (Thrust stem: **02ADN371**, Clamp nut: **02ADB692**)
This is a combination of thrust stem and a clamp nut.
- Spanner wrench:
For 10 mm range models : **02ADB683**
For 25/50 mm range models: **02ADB693**
If required spanner wrench is required for tightening. If using multiple gages, a thrust stem set is required for each gage and one spanner wrench.
- Extension cable
5 m: **21HZA197**
10 m: **21HZA198**
20 m: **21HZA199**
Note 4: Connectable up to 3 pieces, 20 m at maximum.
- Conversion plug
Connection to EH-101P/102P: **21HZA195**
Connection to EH-102Z : **21HZA196**

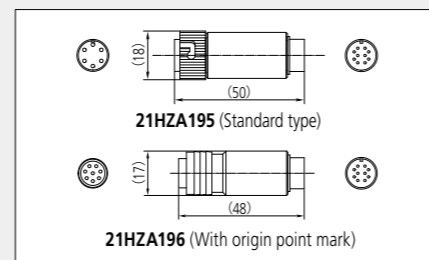

DIMENSIONS

Unit: mm

542-190 / 542-191 / 542-192

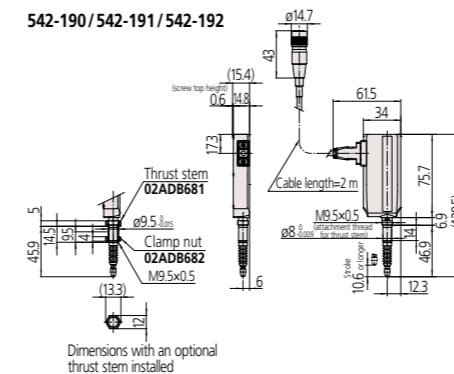

542-193 / 542-194 / 542-195

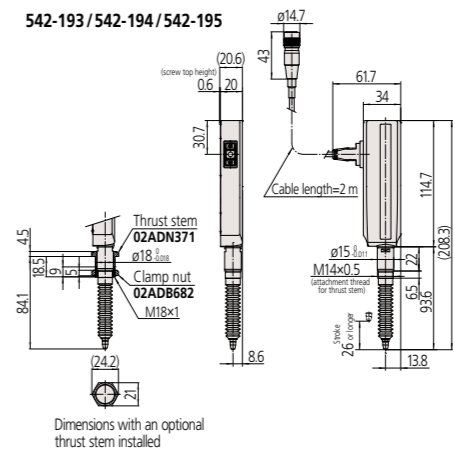

542-196 / 542-197

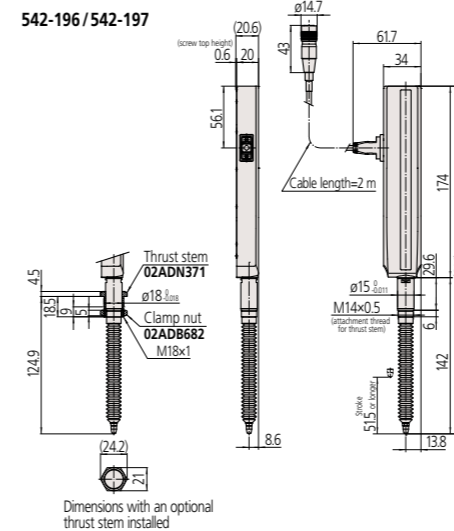

APPLICATION

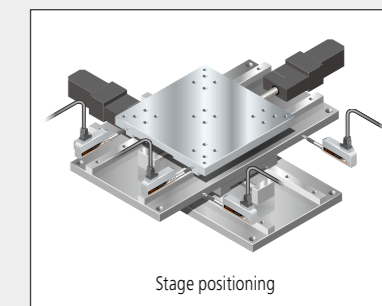
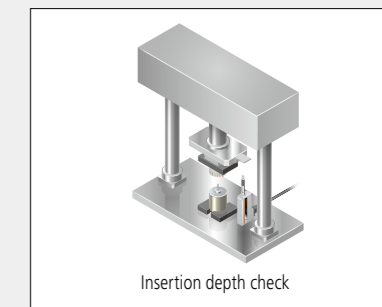
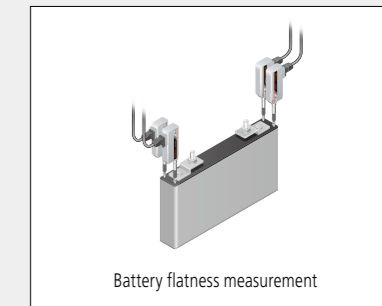

Enables real-time measurement and data management

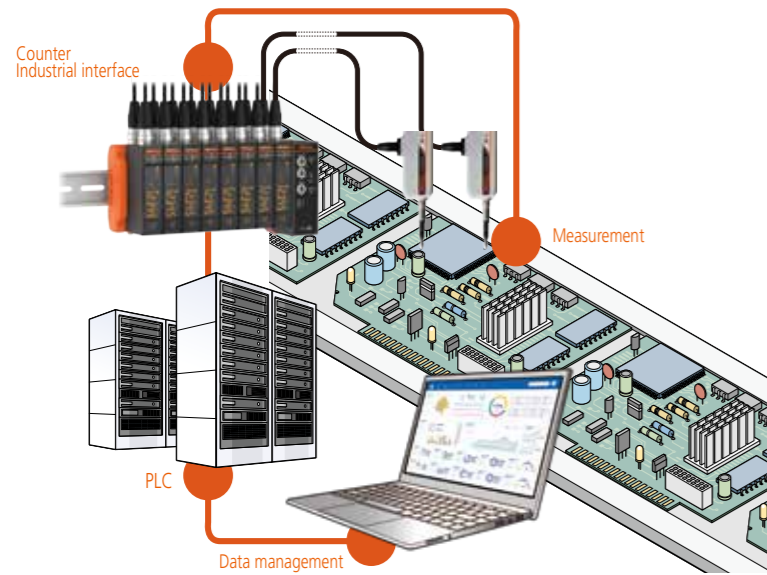

System Configuration

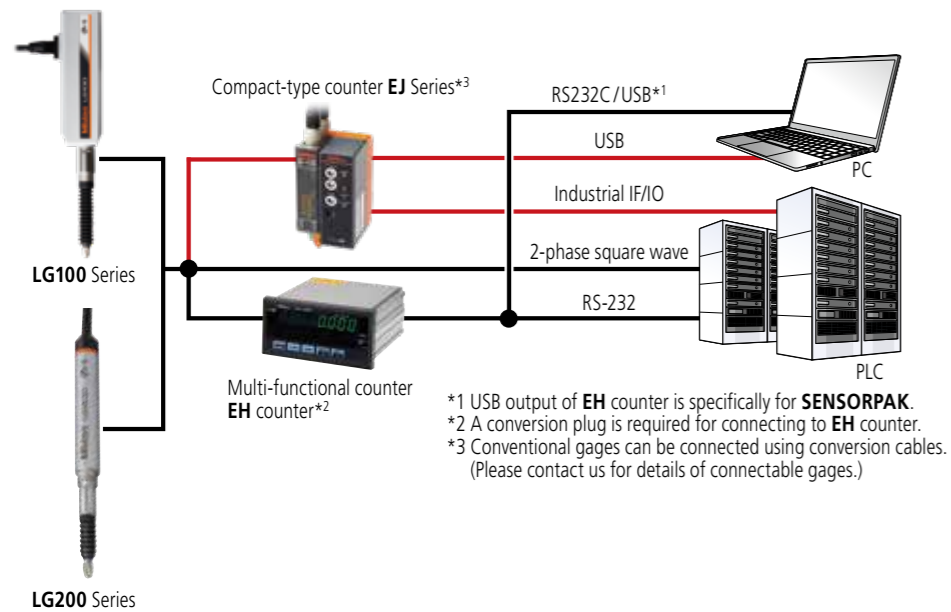

SERIES 542 — Slim Type

LG200



See video from here

- Slimmer body with approx. 1/5 cross section compared with 542-190 (LG100).
- High-accuracy gage head suitable for in-line and in-laboratory use.
- Assures the expected repeatability (2σ) in the full measurement range and the narrow-range precision.
- Protection grade IP67G with sliding durability of 100 million times and more*1 and adoption of highly oil-resistant materials.
 *1 Actual value from in-house tests.
- It can be connected to a compact counter (EJ counter) suitable for in-line use or building into a device or a multifunctional counter (EH counter)*2 suitable for use in measurement rooms.
 *2 A conversion plug is required.



SPECIFICATIONS

Order No.	542-188	542-187	542-186
Measuring range		10 mm	
Resolution	0.1 μ m	0.5 μ m	1 μ m
Measuring accuracy (20 °C)	(0.8 + L/50) μ m L=arbitrary measuring length (mm)	(1.5 + L/50) μ m L=arbitrary measuring length (mm)	
Small range accuracy	0.5 μ m (Arbitrary 20 μ m range)		
Repeatability: 2 σ (20 °C)	0.3 μ m		
Measuring force	Contact point downwards	0.8 N or less	
	Contact point horizontal	0.75 N or less	
	Contact point upwards	0.7 N or less	
Position detection method	Optical transmission-type Linear encoder		
Maximum response speed	400 mm/s	1500 mm/s	
Output signal	90° phase difference, differential square wave (RS-422A equivalent)		
Minimum edge intervals	250 ns (4 MHz)	500 ns (2 MHz)	
Output signal pitch	0.4 μ m	2 μ m	4 μ m
Mass	Approx. 210 g		
Contact point	ϕ 3 mm carbide-tipped (fixing screw: M2.5 (P=0.45) \times 5), standard contact point 901312		
Stem	ϕ 8 mm		
Bearing	Linear ball type		
Output cable length	Approx. 2.5 m (directly from casing)		
Connector	Plug: HR10A-10P-10P (HIROSE), Compatible receptacle: HR10A-10R-10S (HIROSE), Compatible connector: HR10A-10J-10S (HIROSE)		
Operating temperature (humidity) ranges	0 to 50 °C (RH 20 to 80%, non-condensing)		
Storage temperature (humidity) ranges	-10 to 60 °C (RH 20 to 80%, non-condensing)		
Standard Accessories	Wrench for contact point: 538610		

DIMENSIONS

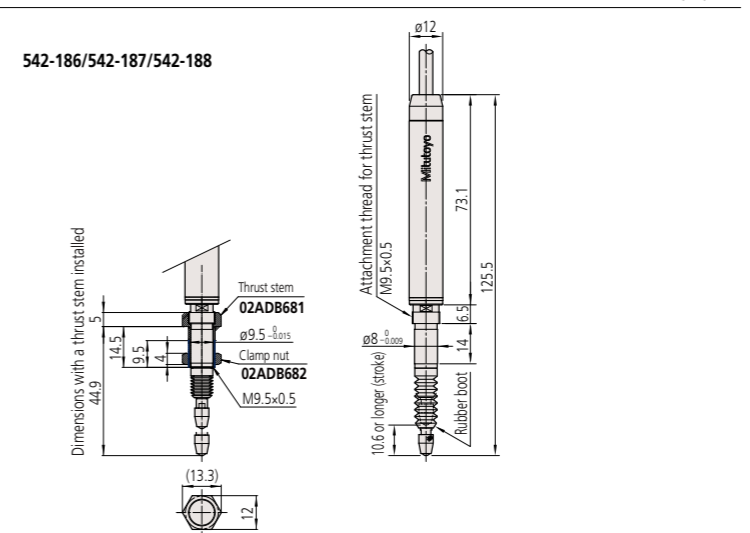

Connector

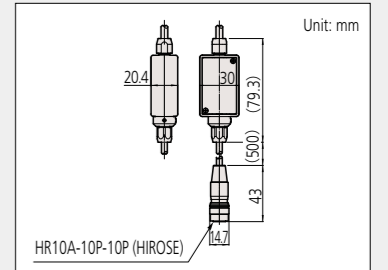

Optional Accessories

- Air lifter: 02ADE230
- Note 1: Required air pressure: 0.2 to 0.4 MPa (With a 0.1 μ m resolution type: 0.2 MPa)
- Note 2: Spindle extends when air is supplied.



- Rubber boot: 21HAA331 (spare)
- Thrust stem set: 02ADB680 (Thrust stem: 02ADB681, Clamp nut: 02ADB682) This is a combination of thrust stem and a clamp nut.
- Spanner wrench: 02ADB683 If required spanner wrench is required for tightening. If using multiple gages, a thrust stem set is required for each gage and one spanner wrench.

Thrust stem set/Spanner Wrench



- Extension cable
 5 m: 21HZA197
 10 m: 21HZA198
 20 m: 21HZA199
 Note 3: Connectable up to 3 pieces, 20 m at maximum.
- Conversion plug
 Connection to EH-101P/102P: 21HZA195
 Connection to 542-073 : 21HZA196
 Note: Connectable to EH-102Z but the function of reference point detection is disabled.

Custom order example

- Measuring force change
- Cable length change (less than 2 m)
- Connector change

LGH

- This series has achieved very high accuracy combined with a resolution of 0.01/0.005 μm (according to model), practically equivalent to that of a laser interferometer, and a wide measuring range of 10 mm.
- A compact body design makes a significant contribution to a downsizing of this gage itself, which is best suited for calibration/evaluation of master gages as well as measurement of high-precision parts and as a length measuring sensor incorporated into high-precision positioning/control units.
- A low measuring force model is available for those applications where measurement of easily deformed or damaged workpieces is required.
- Every LGH Series gage is bundled with a dedicated counter.



- This model is equipped with a newly developed optical reflection-type linear encoder, achieving an excellent resolution of 0.01 μm, a measuring accuracy of 0.2 μm and a measuring range of 10 mm at a low price.
- Maximum operating speed has been improved by a factor of 2.8 times (250 mm/s → 700 mm/s) while maintaining very high accuracy.

- This model is equipped with a newly developed ultra-high precision transmission type linear encoder, achieving the outstanding resolution of 0.005 μm (5 nm).
- Exceptional measuring accuracy of 0.1 μm has been attained over the wide measuring range of 10 mm. This series is most suited for calibration/evaluation of master gages where its wide measuring range is a great advantage.



Dedicated counter

TYPICAL APPLICATIONS

Master gage calibration/evaluation



Inspection of high-precision parts



Needle contact-point mounting example

DIMENSIONS

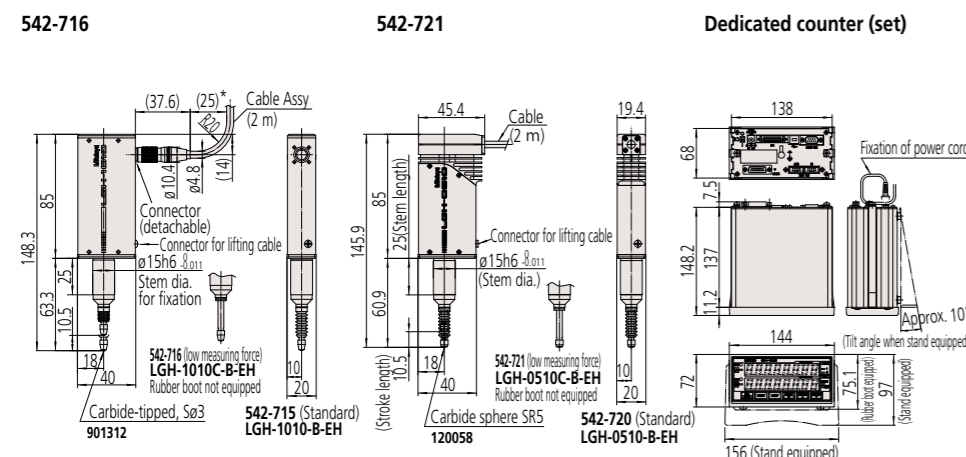

* Minimum bending radius or minimum dressed dimension

Optional Accessories

Measuring stand: 971750

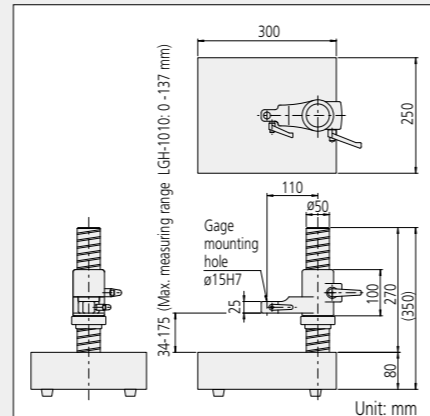

• Release with damper: 971753

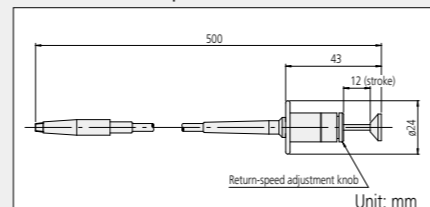

• I/O output connector: 02ADB440



• SENSORPAK : No.02NGB070

*Refer to page 38 for details.



• Rubber boot: 238772 (Spare for 542-715 and 542-720)

SPECIFICATIONS

Type	Resolution 0.01 μm/Accuracy 0.2 μm model		
Order No.	542-715 (Standard)	542-716 (Low measuring force)	
Measuring range	10 mm		
Resolution	0.01 μm (0.05 μm, 0.1 μm, 0.5 μm, 1 μm can be selected from the counter)		
Measuring accuracy (20 °C)*1	0.2 μm		
Repeatability (20 °C)*1	0.1 μm (2σ)		
Retrace error (20 °C)*1	0.1 μm		
Measuring force	Contact point downwards	0.65 N or less	Approx. 0.12 N
	Contact point horizontal	0.55 N or less	Not applicable
	Contact point upwards	0.45 N or less	Not applicable
Position detection method	Optical reflection type linear encoder		
Detectable operation speed	In normal measurement: 700 mm/sec; for peak detection: 120 mm/sec		
Mass of gage head	Approx. 370 g		
Contact point	Carbide tipped, Sφ3 mm (M2.5 (P=0.45) ×5 mm), standard contact point 901312		
Stem	φ15 mm		
Bearing	Linear ball type		
Output cable length	Approx. 2 m		
Operating temperature/humidity ranges	0 to 40 °C (Reference temperature 20 °C)/20 to 80% RH (non-condensing)		
Storage temperature/humidity ranges	-10 to 60 °C/20 to 80% RH (non-condensing)		
Counter Specifications			
Display range	±999.99999 mm		
Functions	Zero-set, preset, direction switch, tolerance judgment (3 steps/5 steps), RS-LINK		
Peak hold function	Yes		
Interface	RS-232C, USB (only for SENSORPAK), Digimatic (Printer: DP-1VA LOGGER)*3, I/O Connector		
External output	• RS-232C: counting data • Digimatic output: counting data*3 • I/O connector: counting data (simplified BCD), tolerance judgment result, simplified analog output		
External control	Zero-set, preset, data hold, peak measurement mode selection, peak clear		
Power supply	Supplied AC Adapter, or +12 to 24 V DC, max. 700 mA		
Power consumption	8.4 W (max. 700 mA), Ensure at least 1 A power supply per unit.		
Mass of counter	Approx. 900 g (AC Adapter excluded)		
Standard accessories	Wrench for contact point, rubber boot, stand, washer (for counter), AC Adapter, AC cord, DC plug, user's manual, inspection certificate		

Type	Resolution 0.005 μm/Accuracy 0.1 μm model		
Order No.	542-720 (Standard)	542-721 (Low measuring force)	
Measuring range	10 mm		
Resolution	0.005 μm (0.01 μm, 0.05 μm, 0.1 μm can be selected from the counter)		
Measuring accuracy (20 °C)*1	0.1 μm		
Repeatability (20 °C)*1	0.02 μm (2σ)		
Retrace error (20 °C)*1	0.05 μm		
Measuring force	Contact point downwards	0.65 N or less	Approx. 0.1 N
	Contact point horizontal	0.55 N or less	Not applicable
	Contact point upwards	0.45 N or less	Not applicable
Position detection method	Ultra-high accuracy transmission type linear encoder		
Detectable operation speed	In normal measurement: 250 mm/sec		
Mass of gage head	Approx. 370 g		
Contact point	Carbide sphere SR5 (M2.5 (P=0.45) ×5 mm), standard contact point 120058		
Stem	φ15 mm		
Bearing	Linear ball type		
Output cable length	Approx. 2 m		
Operating temperature/humidity ranges	15 to 25 °C (Reference temperature 20 °C)/30 to 60% RH (non-condensing)		
Storage temperature/humidity ranges	-10 to 60 °C/20 to 80% (non-condensing)*2		
Counter Specifications			
Display range	±99.999995 mm		
Functions	Zero-set, preset, direction switch, tolerance judgment (3 steps/5 steps), RS-LINK		
Peak hold function	No		
Interface	RS-232C, USB (only for SENSORPAK), Digimatic (Printer: DP-1VA LOGGER)*3, I/O Connector		
External control	• RS-232C: counting data • Digimatic output: counting data*3 • I/O connector: counting data (simplified BCD), tolerance judgment result, simplified analog output		
External control	Zero-set, preset, data hold		
Power supply	Supplied AC Adapter, or +12 to 24 V DC, max. 700 mA		
Power consumption	8.4 W (max. 700 mA), Ensure at least 1 A power supply per unit.		
Mass of counter	Approx. 900 g (AC Adapter excluded)		
Standard accessories	Wrench for contact point, rubber boot, stand, washer (for counter), AC Adapter, AC cord, DC plug, user's manual, inspection certificate		

*1 Applies when used with counter.

*2 The storage temperature/humidity ranges after unpacking are the same as the operating temperature/humidity ranges.

*3 Digimatic output shall be up to 6 digits of data. For data of 7 digits or more, all digits will not be output to the display.

LGS-1012P

Digimatic

ABSOLUTE™

- ABSOLUTE electrostatic capacitance type encoder makes it possible to maintain the reference point even when the power is switched off.
- Excellent protection against dust and splashing water (IP66) on the factory floor.



SPECIFICATIONS

Order No.	575-303	
Measuring range	12.7 mm	
Resolution	10 μm	
Measuring accuracy (20 °C)	15 μm	
Measuring force	Contact point downwards	2.0 N or less
	Contact point horizontal	1.8 N or less
	Contact point upwards	1.6 N or less
Position detection method	ABSOLUTE electrostatic capacitance type linear encoder	
Response speed	Unlimited (not applicable to scanning measurement)	
Output	Digimatic output	
Mass	Approx. 190 g	
Protection Level	Equivalent to IP66 (only gage head)	
Contact point	ø3 mm carbide-tipped (fixing screw: M2.5 (P=0.45) ×5), standard contact point: 901312	
Stem	ø8 mm	
Bearing	Plain type	
Output cable length	2 m (directly extended from the main unit)	
Operating temperature (humidity) ranges	0 to 40 °C (RH 20 to 80%, non-condensing)	
Storage temperature (humidity) ranges	-10 to 60 °C (RH 20 to 80%, non-condensing)	

Order No.	575-313	
Measuring range	0.5 in	
Resolution	0.0005 in	
Measuring accuracy (20 °C)	0.0008 in	
Measuring force	Contact point downwards	2 N or less
	Contact point horizontal	1.8 N or less
	Contact point upwards	1.6 N or less
Position detection method	ABSOLUTE electrostatic capacitance type linear encoder	
Response speed	Unlimited (not applicable to scanning measurement)	
Output	Digimatic code	
Mass	Approx. 190 g	
Protection Level	Equivalent to IP66 (only gage head)	
Contact point	ø3 mm carbide tipped (fixing screw: 4-48 UNF), standard contact point: 21BZB005	
Stem	ø9.52=3/8 in DIA	
Bearing	Plain type	
Output cable length	2 m (directly extended from the main unit)	
Operating temperature (humidity) ranges	0 to 40 °C (RH 20 to 80%, non-condensing)	
Storage temperature (humidity) ranges	-10 to 60 °C (RH 20 to 80%, non-condensing)	

DIMENSIONS

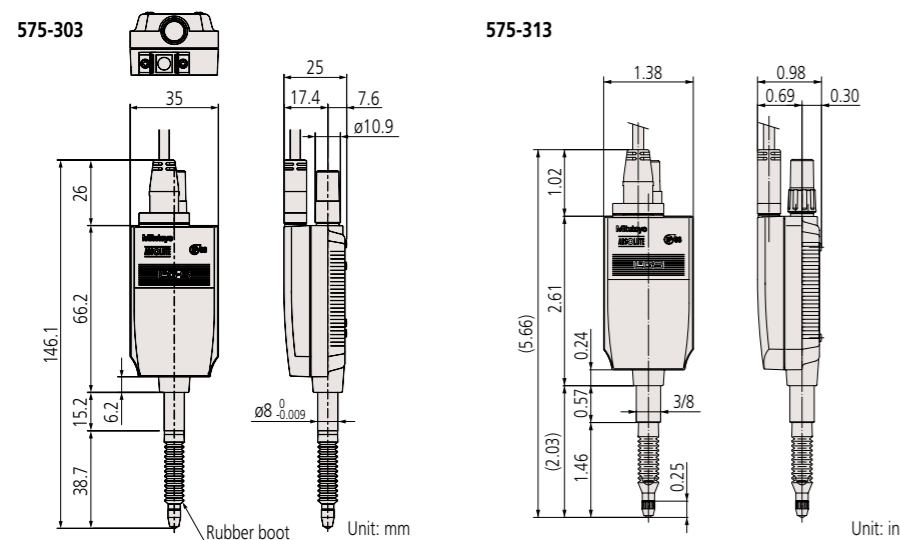

Connector

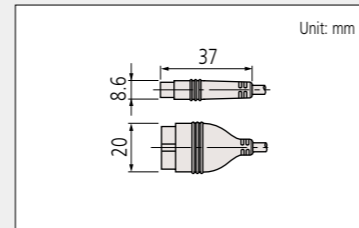

Optional Accessories

- Rubber boot (spare): **238774**
- Air lifter (metric): **903594**
- Air lifter (inch): **903598**
- SPC cable extension adapter: **02ADF640**
- Extension cable for Digimatic gages (0.5 m): **02ADD950**
- Extension cable for Digimatic gages (1 m): **936937**
- Extension cable for Digimatic gages (2 m): **965014**

Note: When connecting an extension cable, an SPC cable extension adapter is required.

Custom order example

- Measuring force change
- Cable length change
- Connector change

Head Specifications (Accessories)

Optional Accessories

Air Lifter

- Advances or retracts the spindle of a gage head by using a pneumatic cylinder.
- Automatic measurement is possible by using a solenoid valve.



For LGS: 903594 (mm), 903598 (in)

Air lifting unit LGS

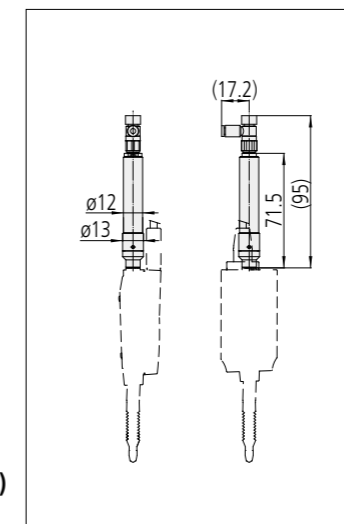

For 25 mm LG100: 02ADE250

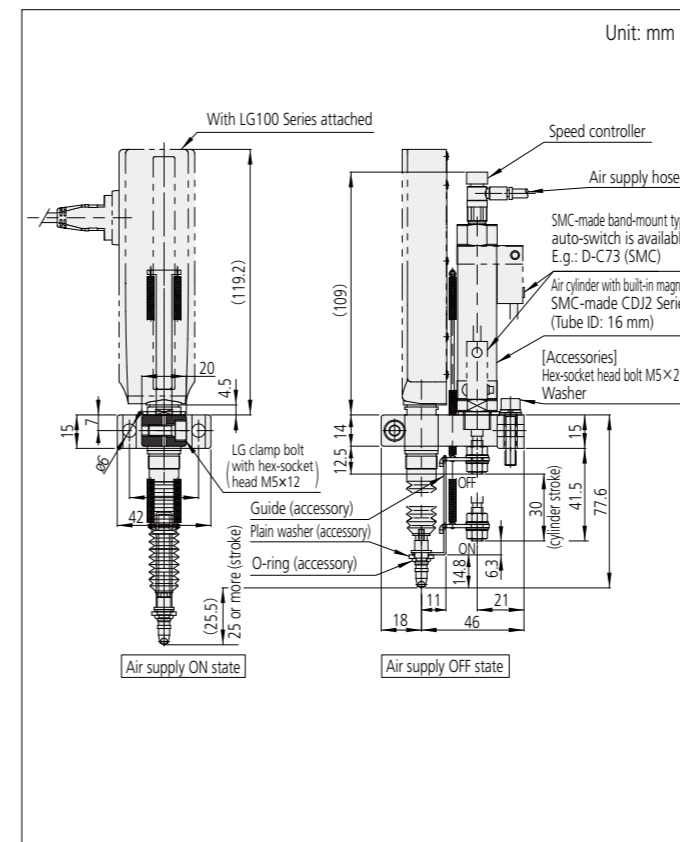

For 10 mm LG100/LG200: 02ADE230

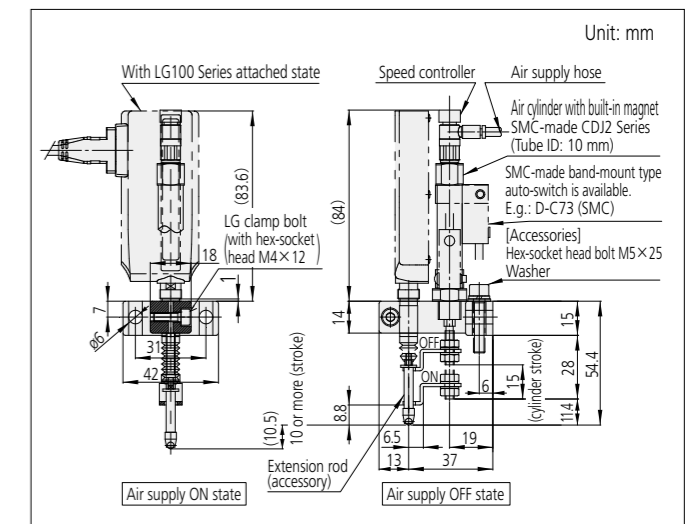

For 50 mm LG100: 02ADE270

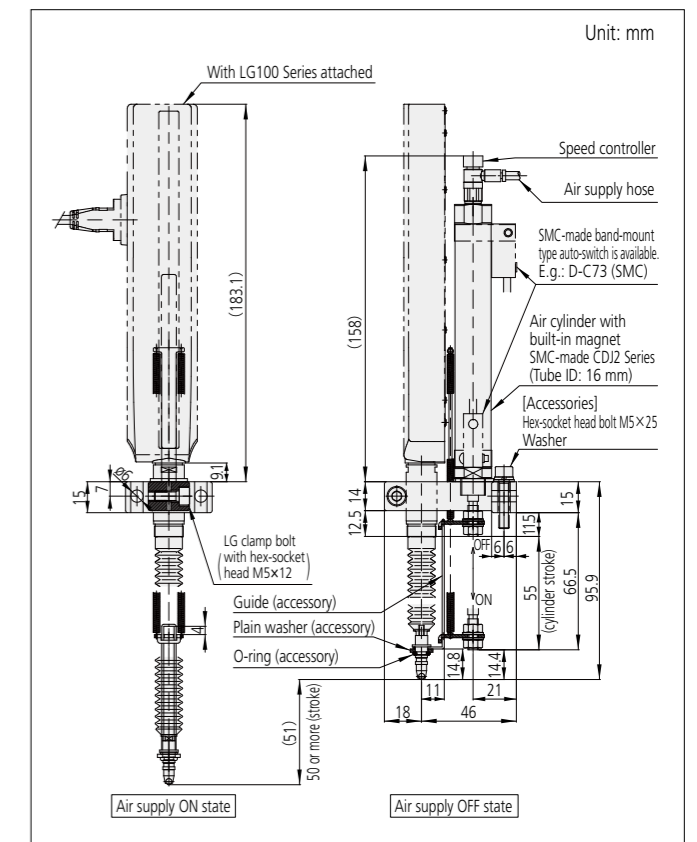

SPECIFICATIONS

Order No.	903594	903598	02ADE230	02ADE250	02ADE270
Stroke	10 mm	0.4 in	10 mm	25 mm	50 mm
Compatible gage head	LGS-1012P		LG100/LG200 Series (10 mm only)		
Air supply	0.5 MPa		0.2 to 0.4 MPa (With a 0.1 μm resolution type: 0.2 MPa)*		
Mass	60 g		150 g	250 g	300 g

* An overspeed error may occur depending on the usage environment and conditions. In case of an error, adjust the air pressure and flow rate to be used.

Optional Accessories

Spare rubber boot

Protects the spindle bearing of a gage head from dust.



SPECIFICATIONS

Order No.	Compatible Gage head
21HAA331	LG100/LG200 (for 10 mm range model)
21HZA176	LG100 (for 25 mm range model)
21HZA184	LG100 (for 50 mm range model)
238774	LGS-1012P

Extension signal cable for LG100/LG200

A signal cable from the head to the receiver circuitry can be extended. Maximum number of connectable cables is limited to 3, and the maximum total extension length is limited to 20 m. Custom order: Flexible cable type. Custom order: Customizable cable length.



SPECIFICATIONS

Order No.	Cable length
21HZA197	5 m
21HZA198	10 m
21HZA199	20 m

Digimatic cable extension adapter

02ADF640 Mass: 15 g. This adapter can be used when the **LGS-1012P** gage head is to be connected to a display unit where the provided cable length is not sufficient for this connection.

- Available for **LGS-1012P**.
- Available for **EC-101D, EH-102D**.
- Do not join more than one piece of this product together for use.

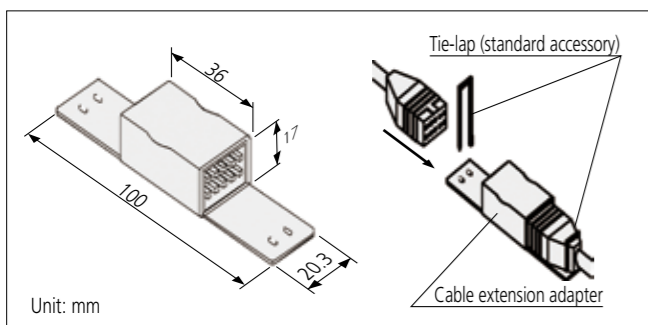

Lifting lever and attachment holder

This holder is attached between the spindle and the contact point for fixing the lifting lever.

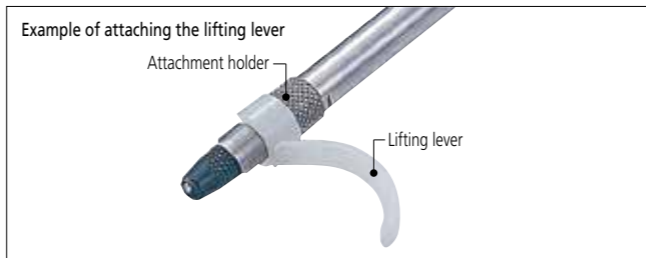

SPECIFICATIONS

Order No.	
02ADG181	Attachment holder
137693	Lifting lever

Extension cable for Digimatic gages

Order No.	Cable length
02ADD950	0.5 m
936937	1 m
965014	2 m



Optional Accessories

Measuring stand



Granite comparator stand BSG-30HX 215-156-10

Base material	Granite
Base size (mm)	W 250×D 300×H 95
Base flatness	3.5 μm
Fine adjustment	Square thread
Stem size (mm)	ø20, ø9.53, ø8 with bush

LG100 25 mm/50 mm. When using the stand at 25 mm/50 mm stroke, separately obtain a ø15 bushing (**21JAA331**).



Comparator stand BSC-30HX 215-505-10

Base material	Hardened steel, Grooved measuring stage
Base size (mm)	W 179×D 255×H 89 (Measuring stage □150×H25)
Base flatness	2.3 μm
Fine adjustment	Square thread
Stem size (mm)	ø20, ø9.53, ø8 with bush

LG100 25 mm/50 mm. When using the stand at 25 mm/50 mm stroke, separately obtain a ø15 bushing (**21JAA331**).

Measuring stand for Laser Hologage 971750

This **LGH** stand greatly helps the gage to achieve high accuracy. Mass: 25 kg

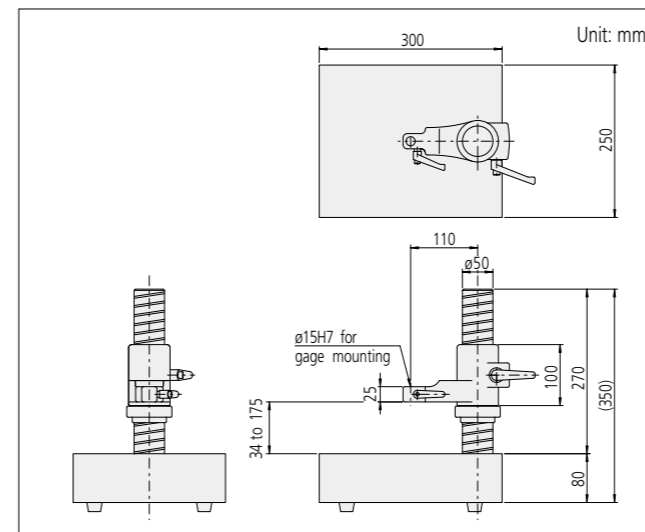

Mounting holder A, B

Useful when the **LGH** is mounted on an alternate fixture rather than the regular measuring stand.

Holder A **971751** Mass: 250 g
Holder B **971752** Mass: 180 g

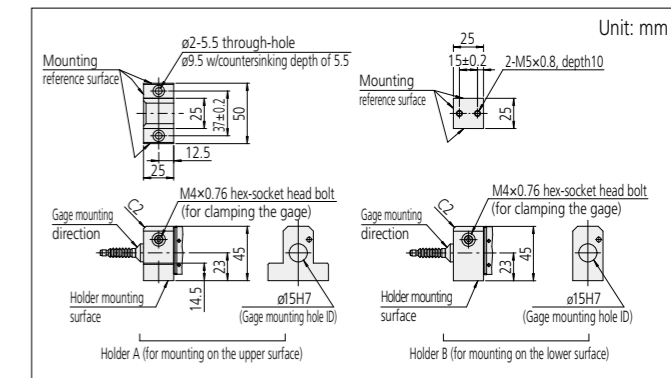

Release with damper

Spindle-lift release for the **LGH**. A sudden drop of the spindle is prevented by the return-speed adjustment knob.

971753 Mass: 50 g

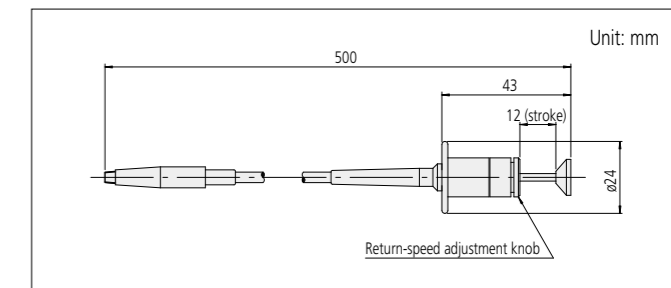

Head Specifications

Differential square-wave

Model (Resolution)	LG100/LG200 (0.1 μm)	LG100/LG200 (0.5 μm)	LG100/LG200 (1 μm)
Output signal	90° phase difference, differential square wave (RS-422A equivalent)		
Signal pitch	0.4 μm	2 μm	4 μm
Minimum edge interval	250 nsec		500 nsec
Output signal level	+5 V (4.8 to 5.2 V, 80 mA) $\bar{0}A, \bar{0}\bar{A}, \bar{0}B, \bar{0}\bar{B}$: TTL, line driver output, AM26LS31 or equivalent		
Plug type	HR10A-10P-10P (HIROSE)		
Compatible socket	HR10A-10R-10S (HIROSE)		
Recommended receiver	Differential input, line receiver, AM26LS32		
Gage connecting cable length	2 m; directly connected to the gage		
Extension cable length	Max. 20 m (extension cables of 5, 10 and 20 m in length are available)		
Error output	See the "Timing chart (occurrence of error)" below		
Voltage/Consumption	+5 V (ripple voltage 0.2 Vpp max.)/80 mA		

Output pin assignment

- Output plug HR10A-10P-10P (HIROSE)
- Pin assignment

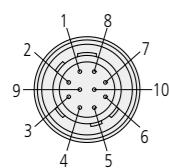

Pin No.	Assignment	Pin No.	Assignment
1	PA	7	N.C.
2	P \bar{A}	8	P \bar{Z}
3	N.C.	9	+5 V*
4	PB	10	GND
5	P \bar{B}	Shell	FG
6	N.C.		

* Power supply to the gage head

Timing chart (normal)

- Real-time pulse output (Phase-A wave advances when the spindle is retracted.)

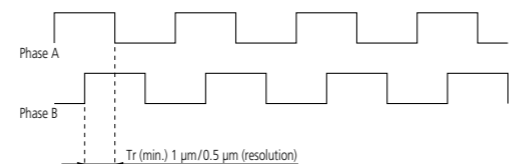

- Output condition: Spindle speed ≤ 250 mm/s*2
- Minimum edge-to-edge interval = Tr
- Output delay time*1: Max. 1 μs

Timing chart (occurrence of error)

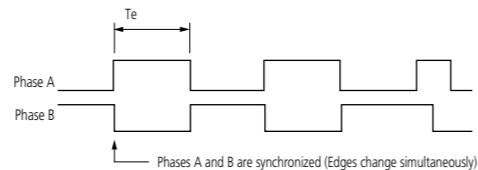

- Output condition: Gage heads will identify an error under the following conditions and produce an output as described above.
 - Gage response speed*3 < Spindle speed
 - At a disturbance such as interference, vibration, etc.
- Minimum width of output pulses = Te

- *1 Output delay time: Time until the counting pulse catches up to the spindle position.
 *2 The actual limit of real-time pulse output will be depreciated to this value.
 This is because actual detection signals unavoidably contain acceleration components in association with the spindle motion as well as error components from a little noise included in the signal itself. As a result, some burst pulses at a speed below the ideal conditions (i.e. ideal signal form at constant speed) may be generated.
 *3 Gage respond speed: Refer to the specifications section in the User's Manual.

[IMPORTANT]

- Since any output during an error condition cannot be used as the attribute data, it is necessary to detect the error condition at the reception circuitry side.
- It is recommended to design user circuitry based on an IC chip that is capable of counting at 5 Mcps (equivalent to square wave of 1.25 MHz) or greater.

LG100 origin point mark applied Timing chart (normal)

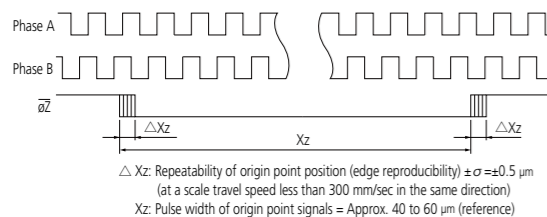

ΔXz : Repeatability of origin point position (edge reproducibility) $\pm \sigma \approx \pm 0.5 \mu\text{m}$ (at a scale travel speed less than 300 mm/sec in the same direction)
 Xz: Pulse width of origin point signals = Approx. 40 to 60 μm (reference)

$\bar{0}Z$ with origin point signals is only output.

Minimum edge-to-edge interval/pulse width under each condition

Model	Resolution	Tr	
		Tr (real-time output)	Tr (error output)
LG100	1 μm	0.4 μs	0.4 μs
	0.5 μm	0.2 μs	0.4 μs
	0.1 μm	0.2 μs	0.4 μs

Head Specifications

Digimatic code

1. Pin assignments and signals

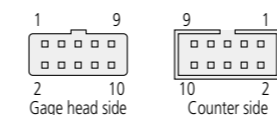

• Compatible socket:
Sumitomo 3M: V Low-Proheader
Model: 7610-5002XX or equivalent

Pin No.	Signal	I/O	Description
1	GND	—	Signal ground
2	DATA	Output	Measurement data-output terminal
3	CK	Output	Synchronized clock-output terminal
4*	N.C.	—	Not used
5	REQ	Input	Input for data transmission request from external device
6*	ORIG	Input	Input for absolute-origin setting signal
7*	N.C.	—	Not used
8*	N.C.	—	Not used
9*	+5 V	—	Power supply (+5 V \pm 10%)
10*	GND (F.G.)	—	Frame ground

* LGS uses a unique specification.
All others use the common Digimatic output specification (10-pin, square).

2. I/O electrical specifications

- Output terminal format: CK, DATA
 - N-channel open drain
 - Maximum output current: 400 μA max. (when $V_{OL} = 0.4$ V)
 - Output withstand voltage: -0.3 V to 7 V
- Input terminal format: REQ, ORIG
 - Pull-up CMOS input
 - Internal power supply voltage: Vdd = 1.35 to 1.65 V
 - Pull-up resistance: R1 = 10 to 100 K Ω
 - "H" level input voltage: $V_{IH} = 1.1$ V min.
 - "L" level input voltage: $V_{IL} = 0.3$ V max.

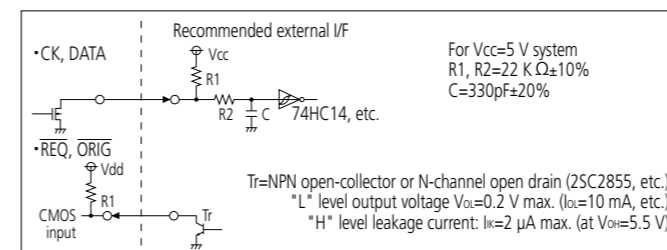

Note: Since the power supply voltages are different between the gage side and the external device side, be sure to use an open collector or open drain circuit. Do not use CMOS output or similar.

3. Data format

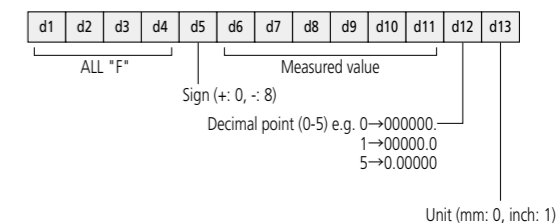

- Data is output as 13-digit (52-bit) based on 4 bits=1 digit.
- Data is output in order from d1 to d13. Each digit is output in the order of LSB to MSB.

4. Timing chart

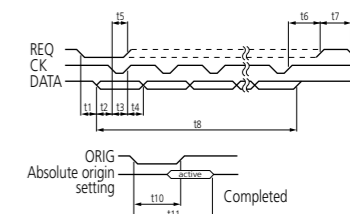

Standard (for reference)

Symbol	min.	max.
t1*	0	2 sec
t2	15 μs	—
t3	100 μs	—
t4	100 μs	—
t5	0	—
t6*	—	—
t7*	—	—
t8*	—	—
t10*	1.5 s	—
t11*	—	—

LGS

Symbol	min.	max.
t1*	30 μs	95 ms
t2	15 μs	—
t3	100 μs	—
t4	100 μs	—
t5	0 μs	—
t6*	—	100 μs
t7*	100 μs	—
t8*	—	30 ms
t10*	1.5 s	—
t11*	—	4 s

- Note 1: The specifications indicated by an asterisk (*) are applicable only to LGS. All other Digimatic output specifications are common to all models.
 Note 2: Read data only when CK is at the "L" level.
 Note 3: Do not input REQ signal (fixed at "H") while the absolute origin is being set (during t11).
 Note 4: If t5, t6 and t7 are satisfied and REQ is continuously input, an output is obtained from LGS at intervals of approximately 95 ms.
 Note 5: Start inputting ORIG and REQ after two or three seconds have elapsed (the estimated time required for internal circuit/sensor to stabilize) following power-on.

Q Question

What is the absolute position origin point?

A Answer

The absolute position origin point is known as the origin point (0 point) that will never vanish even when power is turned off. The LGS Series is equipped with the absolute scale (electrostatic capacitance type ABS scale) that can set the absolute position origin point, thus always outputting the contact point position in reference to the last origin point when power is turned on again. This removes the necessity for adjustment with the master every time power is turned on and contributes significantly to automation of measurement.

Absolute Scale Device (Electrostatic capacitance type ABS scale device)

- An absolute address is applied to individual absolute scales inside the main scale just like rail ties are numbered. A measured value is displayed by reading this absolute address from a slider position.

- The system uses 3 scales with a different wavelength while applying an absolute address on each scale.

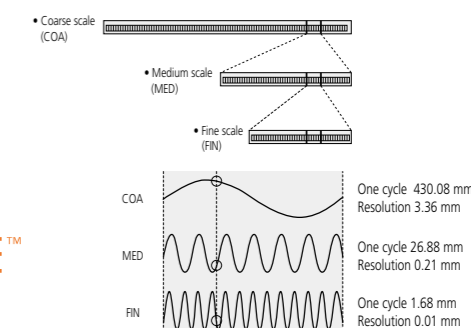

ABSOLUTE™

Counter Specifications

EJ-102N Counter, Interface Unit: CC-Link, PROFINET, EtherNet/IP, EtherCAT, USB



Features

- A small, high-speed, space-saving counter for linear gage suitable for in-line and in-laboratory use. It brings visibility into the production site, improves productivity, and enables data accumulation.
- Up to 8 compact counters (EJ counters) can be linked providing the capacity to connect up to 16 gages.
- On a DIN rail, each unit can be connected directly without using cables, so it takes up minimal space. All linked units and gages can be driven by a single power source.

- Data can be output through an industrial interface (CC-Link) by linking a compact counter (EJ counter) with an interface unit. Constant data monitoring and positional management are performed. A USB interface is also provided for easy connection with a computer.
- Enables sum difference operations between 2 gages connected to the same counter.

SPECIFICATIONS

Order No.	542-080	542-081
Model	EJ-102N	
Unit	mm	inch/mm
Resolution	0.005, 0.001, 0.0005, 0.0001 (mm)	0.0002, 0.00005, 0.00002, 0.000005 (inch)/ 0.005, 0.001, 0.0005, 0.0001 (mm)
Number of linear gage connection ports	2	
Supported gage signal	Differential square wave, differential square wave with reference point mark	
Maximum input frequency	5 MHz	
User Interface	Display: Negative sign + 8 digits and indicator (1 gage value displayed, manually switchable)	
External I/O	Number of I/O ports	Input: 4 ports (Ch switch, peak clear, data hold, preset) Output: 4 ports (Err/ALLGO, Tolerance judgment)
	Compatible communication standards	CC-Link, USB (Supported with optional interface units)
Max. number of linked units	EJ Counter 8 units + 1 (optional) interface unit (Max. number of linear gage connections: 16)	
Power supply	Input voltage	10 V to 27 V DC
	Power consumption	1 unit only: 3 W or less (Includes 2 linear gages) Max. number of links: 30 W or less (Interface unit and 16 linear gages included)
Operating temperature (humidity) ranges	0 to 50 °C (RH 20 to 80%, non-condensing)	
Storage temperature (humidity) ranges	-10 to 60 °C (RH 20 to 80%, non-condensing)	
Mass	Approx. 120 g	

Connectable linear gage Series	Conversion cable (optional)
LG100	Not necessary
LGF-Z	Necessary (21HZA194)
LGF/LGK/LGB/LG	Necessary (21HZA193)

Order No.	21HZA186
Model	Interface unit CC-Link
Applicable interface	USB 2.0 Full Speed CC-Link Ver. 1.10 CC-Link Ver. 2.00
User Interface	Display: POWER (green), RUN (green), ERROR (red), EJ-CONNECT (green) Switch: Rotary switch×3 (Exchange number settings×2, communication speed settings×1)
Functions	Common protocols for USB and CC-Link, Readout of current value*, Current value hold (software hold), Parameter setting on EJ counter, Tolerance judgment value settings, Preset value settings, preset/zero-set clear, peak clear, error clear *2 Only Ver. 2.00 is supported with CC-Link.
Power supply	Power is supplied from EJ-102N (542-080/542-081) (Cannot be charged via USB)
Operating temperature (humidity) ranges	0 to 50 °C (RH 20 to 80%, non-condensing)
Storage temperature (humidity) ranges	-10 to 60 °C (RH 20 to 80%, non-condensing)

Order No.	21HZA187
Model	Interface unit PROFINET
Applicable interface	PROFINET RT (RT Class1)/USB 2.0 Full Speed
User Interface	POWER (green), NETWORK (green/red), MODULE (green/red), LINK PORT1 (green), LINK PORT2 (green), EJ-CONNECT (green)
Functions	Common protocols for USB and PROFINET, Readout of current value, Current value hold (software hold), Parameter setting on EJ counter, Tolerance judgment value settings, Preset value settings, preset/zero-set clear, peak clear, error clear
Power supply	Power is supplied from EJ-102N (542-080/542-081) (Cannot be charged via USB)
Operating temperature (humidity) ranges	0 to 50 °C (RH 20 to 80%, non-condensing)
Storage temperature (humidity) ranges	-10 to 60 °C (RH 20 to 80%, non-condensing)

Order No.	21HZA188
Model	Interface unit EtherNet/IP
Applicable interface	EtherNet/IP
User Interface	POWER (green), NETWORK (green/red), MODULE (green/red), LINK PORT1 (green/amber), LINK PORT2 (green/amber), EJ-CONNECT (green)
Functions	Common protocols for USB and EtherNet/IP, Readout of current value, Current value hold (software hold), Parameter setting on EJ counter, Tolerance judgment value settings, Preset value settings, preset/zero-set clear, peak clear, error clear
Power supply	Power is supplied from EJ-102N (542-080/542-081) (Cannot be charged via USB)
Operating temperature (humidity) ranges	0 to 50 °C (RH 20 to 80%, non-condensing)
Storage temperature (humidity) ranges	-10 to 60 °C (RH 20 to 80%, non-condensing)

Order No.	21HZA264
Model	Interface unit EtherCAT
Applicable interface	EtherCAT
User Interface	POWER (green), RUN (green), ERROR (red), L/A IN (green), L/A OUT (red), EJ-CONNECT (green)
Functions	Common protocols for USB and EtherCAT, Readout of current value, Current value hold (software hold), Parameter setting on EJ counter, Tolerance judgment value settings, Preset value settings, preset/zero-set clear, peak clear, error clear
Power supply	Power is supplied from EJ-102N (542-080/542-081) (Cannot be charged via USB)
Operating temperature (humidity) ranges	0 to 50 °C (RH 20 to 80%, non-condensing)
Storage temperature (humidity) ranges	-10 to 60 °C (RH 20 to 80%, non-condensing)

Order No.	21HZA149
Model	Interface unit USB
Applicable interface	USB 2.0 Full Speed
User Interface	POWER (green)
Functions	Readout of current value, Current value hold (software hold), Parameter setting on EJ counter, Tolerance judgment value settings, Preset value settings, preset/zero-set clear, peak clear, error clear
Power supply	Power is supplied from EJ-102N (542-080/542-081) (Cannot be charged via USB)
Operating temperature (humidity) ranges	0 to 50 °C (RH 20 to 80%, non-condensing)
Storage temperature (humidity) ranges	-10 to 60 °C (RH 20 to 80%, non-condensing)

DIMENSIONS

EJ-102N

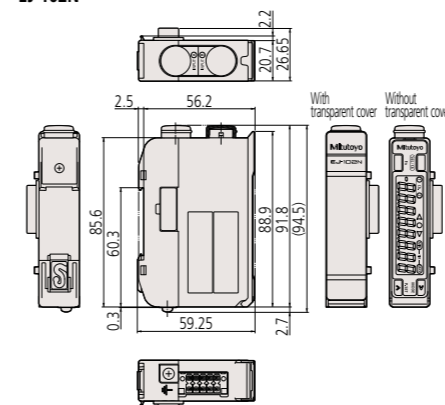

Interface unit CC-Link

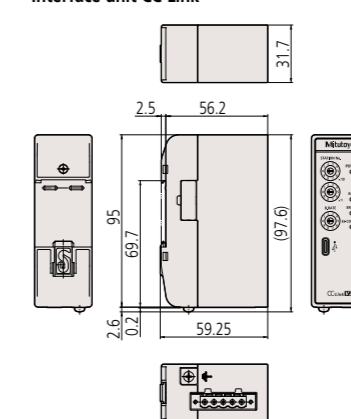

Interface unit PROFINET

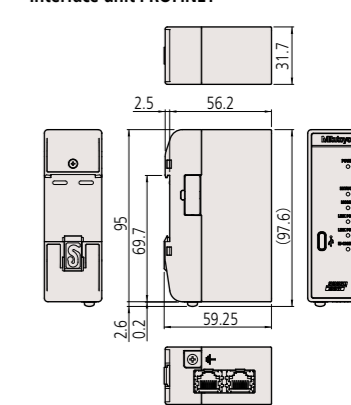

Interface unit EtherNet/IP

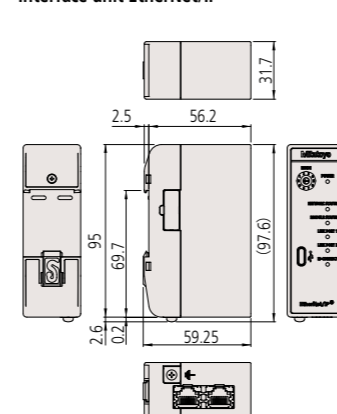

Interface unit EtherCAT

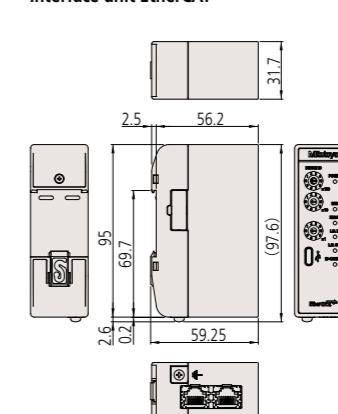

Interface unit USB

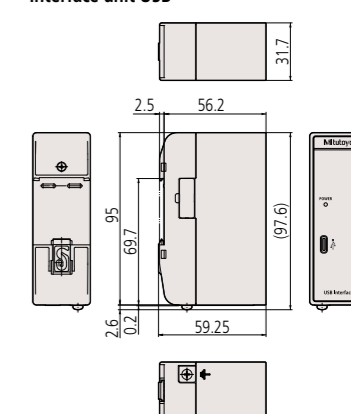

Unit: mm

Note 1: Can be mounted on DIN rail. Case material: PC, POM

SOFTWARE LG QuickSetupTool

A configuration tool is available for use with the EJ counter when connected via the optional USB interface. All kinds of settings normally carried out with counter operating keys can now be easily applied from a computer. Measurement value display and operation results can also be viewed on a PC.

Note 2: This software can be used free of charge and downloaded from the Mitutoyo website. <https://www.mitutoyo.co.jp/eng/contact/products/lg/>

Recommended system environment
 OS: Windows10 Pro 32 bit/64 bit
 Display: 1600x1200 or more
 Memory: 1024 MB or more
 Communication method: USB2.0 (Full speed)
 USB connector: Type C connector
 Note 3: USB device drivers are standard Windows drivers.



Parameter setting



Chart

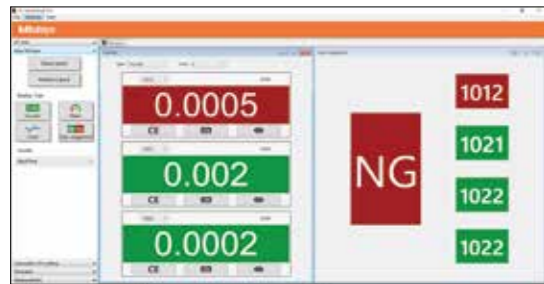

General settings

Optional Accessories

AC adapter
 No.357651



AC cable
 No.02ZAA000*



DC jack with pin terminal for EJ counter
 No.21HZA209*



* Necessary when using the AC adapter

Counter Specifications
EC Counter – Only for Digimatic output



Features

- Employs the DIN size (96x48 mm) and mount-on-panel configuration, which greatly facilitates incorporation into a system.
- Can either produce tolerance judgment output or Digimatic output.

Functions

- Preset
- Tolerance judgment (3 steps)

SPECIFICATIONS

Order No./Model	542-007* EC-101D
Resolution	0.01 mm (±9999.99)/0.0005 in (±99.9995 in)/0.001 in (±999.999 in) 0.001 mm (±9999.999)/0.00005 in (±9.99995 in)/0.0001 in (±99.999 in) [Automatic setting by gage]
Display	Sign plus 6 digits (Green LED)
Tolerance judgment display	LED display (3 steps: Amber, Green, Red)
External output (switching type)	Tolerance judgment output: -NG, OK, +NG (open-collector) Data output: Digimatic output
Control input	External PRESET, external HOLD
Power supply	Voltage: Supplied AC adapter, or 9 to 12 V DC Consumption: 4.8 W (max. 400 mA) Ensure at least 1 A is available per unit.
Operation/storage temperature range	Operation: 0 to 40 °C/Storage: -10 to 50 °C
External dimensions	96 (W) x 48 (H) x 84.6 (D) mm
AC adapter	AC adapter: 12BAR954 AC cable: 12BAK729 (Japan), 12BAK730 (U.S.), 12BAK731 (EU), 12BAK734 (UK), 12BAK732 (China), 12BAK733 (Korea)
Applicable head	LGS, ID
Mass	220 g
Optional accessories	Connecting cable for Digimatic Mini-processor: 936937 (1 m), 965014 (2 m) DC plug PJ-2: 214938 I/O cable (2 m): 21HZA222

* To denote your AC power cable add the following suffixes to the order No.: A for UL/CSA, D for CEE, DC for CCC, E for BS, K for KC, C and No suffix are required for PSE.

DIMENSIONS

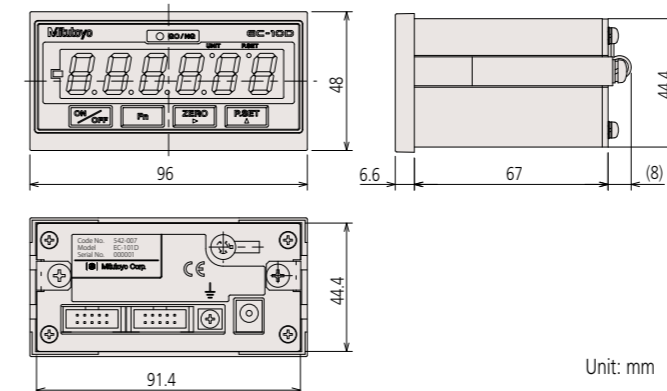

Input/output specifications

- 1) Compatible plug: MIL type connector FAS-10-17 (YAMAICHI), XG4M-1030-T (OMRON)
- 2) Pin assignment

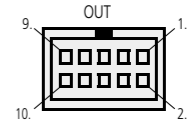

Pin No.	I/O	Description	Function	Optional I/O cable color
1		COM	Connected to the internal GND	Amber/black
2	O	+NG	Tolerance output: The relevant output terminal falls to L.	Amber/red
3	O	GO	At an error display [+NG=-NG=L]	Yellow/black
4	O	-NG		Yellow/red
5	I	HOLD	HOLD input	Bright green/black
6	I	P.SET	PRESET input (to cancel the error)	Bright green/red
Other than the above listed shall be unconnected.				

Note 1: Output from each pin in the Digimatic output mode may differ from those which are described in the table above.
 Note 2: One end of the I/O cable (2 m, optional) consists of separate wires for connection as appropriate. The cable's F.G wire (with solderless terminal, green) should be connected to the grounding terminal of the main unit.

3) I/O circuit

1. Output circuit (-NG, GO, +NG)
 Transistor is "ON" when the open-collector output is "L".

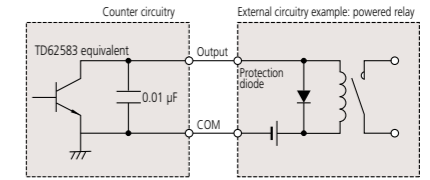

2. Input circuit (PSET, HOLD)
 Input is valid when the line is "L".

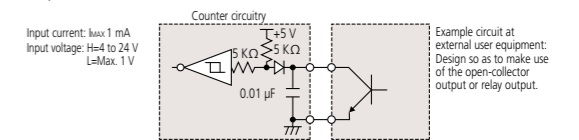

4) Timing chart

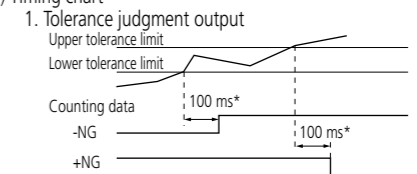

* Varies depending on the gage.

2. External preset/HOLD

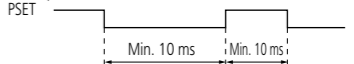

Note: Input is active when L1="H", 0="L".

- 5) Optional I/O cable (2 m)
21HZA222



Digimatic Mini-processor
DP-1VA LOGGER
264-505



EH Counter - Panel mount, Multi-function Type with RS-232C Communication Functions

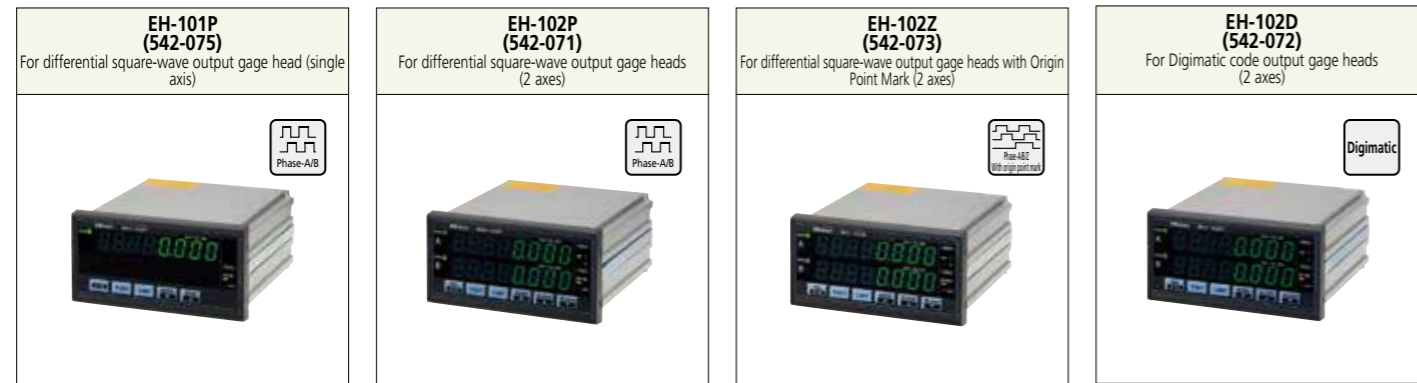

Features

- 1-axis display type, and 2-axis independent display type or 2-axis type that can display sum/difference calculation results are available.
- Multi-functional counter with functions of zero-set, preset, and tolerance judgment
- Equipped with an RS-232C interface as standard. This allows data transfer to a personal computer, etc.
- A multi-point measuring system can easily be built up with the built-in networking function (RS link). (Max. 10 points)
- Employs the DIN size (144x72 mm) and mount-on-panel configuration, which greatly facilitates incorporation into a system.

Functions

Zero-set

Sets the displayed value to 0 at any position of the spindle.

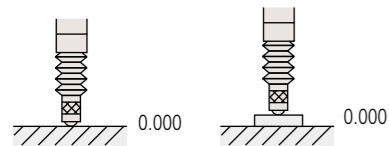

Direction switch

Selects the counting direction of (+) or (-), whichever is convenient with a given direction of spindle movement.

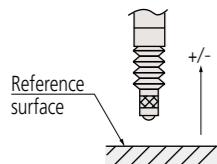

Tolerance judgment indication/output

Sets two (or four) desired tolerances for three (or five) stages. Judgment results can be output to an external device.

Preset

Presets the display at any value. Counting begins at the preset value.

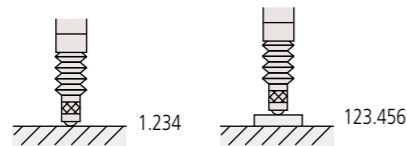

Minimum reading digit change

To improve visualization of measurement data, the least significant digit can be extinguished. (However, the display via RS-232C and printing to a printer are performed down to the least significant digit.)

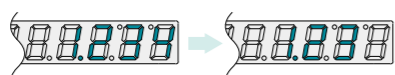

Sum/difference calculation

Enables measurement of thickness or step height using two gages.

External control

Zero set, preset and display hold can be controlled from the I/O terminals.

Error message display

The counter displays an error message when a gage-head over-speed or breakage situation occurs. It outputs the error signal from the I/O terminal.

Peak hold/TIR measurement

Allows switching to the measurement mode for maximum value, minimum value, and run out value (maximum - minimum), in addition to the normal measurement mode.

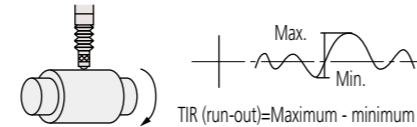

Counting standby (to prevent malfunction at start-up)

This prevents malfunction due to power interruption, etc.

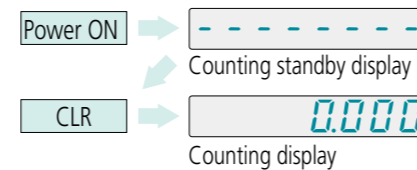

Communication via RS-232C interface

RS-232C allows communication with a personal computer. It allows not only the reading of measured values but also data transmission to the counter and remote operations, such as when changing various settings.

Digimatic output

Digimatic Mini-processor **DP-1VA LOGGER**. (RS-232C function is not available when the gage is connected to **DP-1VA LOGGER**).

SPECIFICATIONS

1-axis input type and 2-axis input type counters are available.

Order No.	542-075*1	542-071*1	542-073*1	542-072*1
Model	EH-101P	EH-102P	EH-102Z	EH-102D
Number of axes to be displayed	1 axis	2 axes		
Maximum input frequency	2.5 MHz (2-phase square wave)			
Resolution	0.01 mm/0.005 mm/0.001 mm/0.0005 mm/0.0001 mm 0.0005 in/0.00005 in/0.00005 in/0.000005 in/0.000005 in (selection by the parameter)			Automatic setting by gage
Tolerance judgment display	LED display (3 steps: Amber, Green, Red/5 steps: Amber, Amber flashing, Green, Red flashing, Red)			
Interface	RS-232C/USB/parameter selection via Digimatic (only DP-1VA LOGGER . Digimatic Mini-processor can be connected) (USB used only with SENSORPAK) Selection by parameter from 3-step, 5-step, or digit BCD Total tolerance judgment output (when tolerance function is enabled) Analog output (1 V to 4 V)			
Input/output	Control output	Open-collector		
	Control input	Display BANK switching, peak mode, presetting, display hold, hold per axis: open-collector		
Power supply	Voltage	Supplied AC adapter (Jack input)		
	Consumption	8.4 W (max. 700 mA) Ensure at least 1 A is available per unit.		
Operating temperature (humidity) ranges	0 to 40 °C (RH 20 to 80%, non-condensing)			
Storage temperature (humidity) ranges	-10 to 50 °C (RH 20 to 80%, non-condensing)			
External dimensions	144 (W) x 72 (H) x 156.7 (D) mm			
Optional Accessories	I/O output connector (with cover): 02ADB440			
Standard Accessories	AC adapter: 357651 /AC cable: 02ZAA000 , AC cable (Japan): 02ZAA000 *1, AC cable (USA): 02ZAA010 *1, AC cable (EU): 02ZAA020 *1, AC cable (UK): 02ZAA030 *1, AC cable (China): 02ZAA040 *1, AC cable (Korea): 02ZAA050 *1			
Applicable gage head	LG100/LG200 A conversion plug 21HZA195 is required*2		LG100/LG200 (A conversion plug 21HZA196 is required)	
Mass	Approx. 760 g	Approx. 800 g	Approx. 800 g	Approx. 800 g

*1 To denote your AC power cable add the following suffixes to the order No.: A for UL/CSA, D for CEE, DC for CCC, E for BS, K for KC, C and No suffix are required for PSE.

For those models of the Order No. with Suffix "1", an AC adapter is not supplied as a standard accessory.

*2 The origin point detection function is disabled.

DIMENSIONS

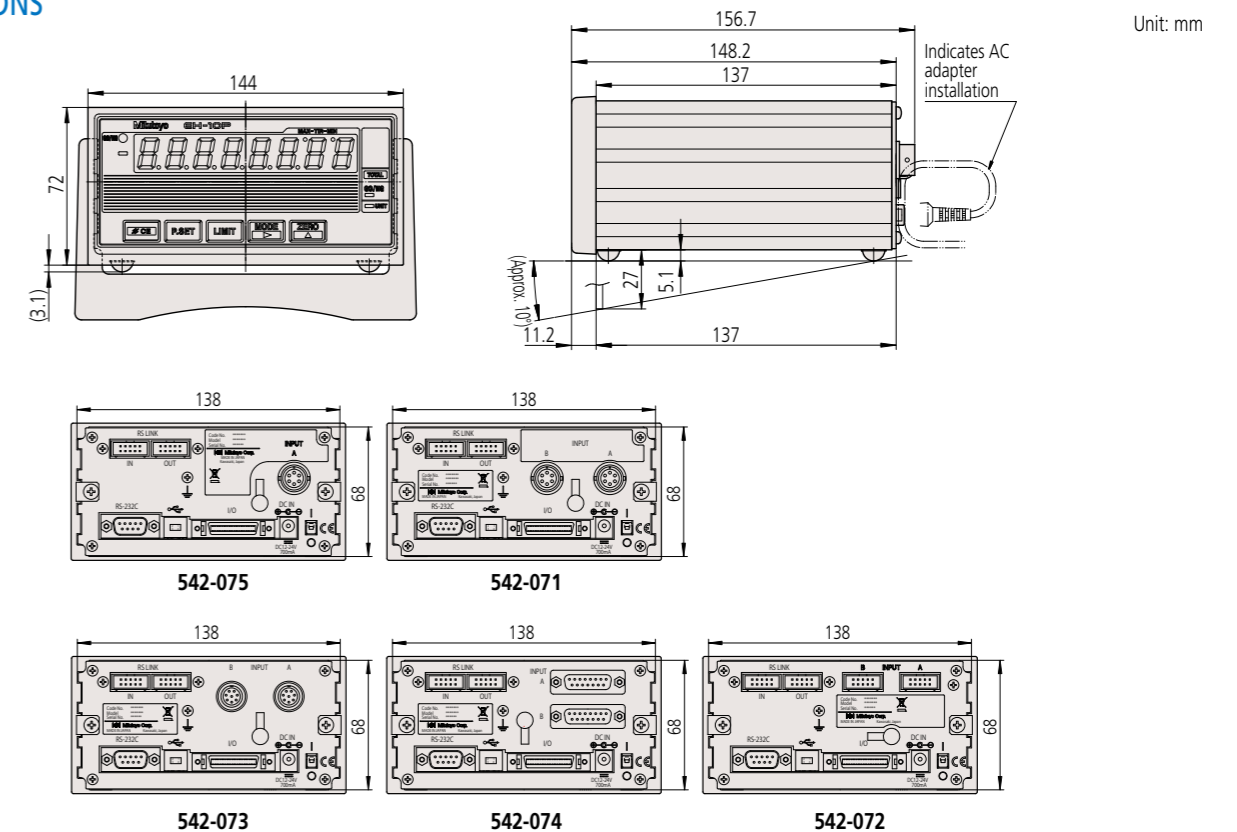

Counter Specifications

BCD Output

Simultaneously outputs at channels [A] and [B] in groups of 4 bits.

1) Timing chart

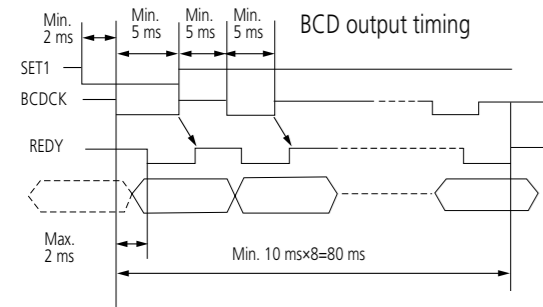

2) Data format

	LSD (Least significant digit)				MSD (Most significant digit)			
	D1	D2	D3	D4	D8			
A/B_bit0	1×10 ⁰	1×10 ⁰				1×10 ⁷	
A/B_bit1	2×10 ⁰	2×10 ⁰				2×10 ⁷	
A/B_bit2	4×10 ⁰	4×10 ⁰				4×10 ⁷	
A/B_bit3	8×10 ⁰	8×10 ⁰				8×10 ⁷	
A/B_SIGN	SIGN	BANK	PEAK1	PEAK2				
	+: H							
	:- L							
	BANK1: L		NOM	PEAK1	PEAK2			
	BANK2: H		MAX	L	L			
			MIN	L	H			
			TIR	H	H			

Bits 0-3	D1	D2	D3	D4	D5	D6	D7	D8
SIGN	L							

- 1 2 3 4 5 6 0 1

Note: Negative logic output is possible for SIGN, BANK, PEAK, DATA (PNo.21=1).

Simple analog output

Monitoring of output waveforms is possible with an analog recorder connected.

1) Output specification

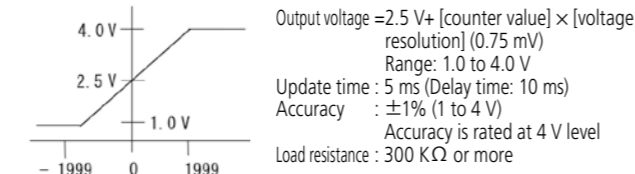

2) Measuring range

Parameter	Measuring range (mm)/Resolution (mm)			
	No.30	10 μm gage	1 μm gage	0.1 μm gage
0	±19.99 (0.01)	±1.999 (0.001)	±0.1999 (0.0001)	
1	±199.90 (0.1)	±19.990 (0.01)	±1.9990 (0.001)	
2	±1999.00 (1)	±199.900 (0.1)	±19.9900 (0.01)	

RS Link* Function

It is possible to connect a maximum of 10 counter units together to carry a maximum of 20 channels of multi-point measurement at a time. For this connection use a dedicated RS link cable; **02ADD950** (0.5 m), **936937** (1 m) or **965014** (2 m) (The maximum total length of RS link cables permitted for the entire system is 10 m.)

* Patent registered (Japan, U.S.), Patent pending (E.U.)

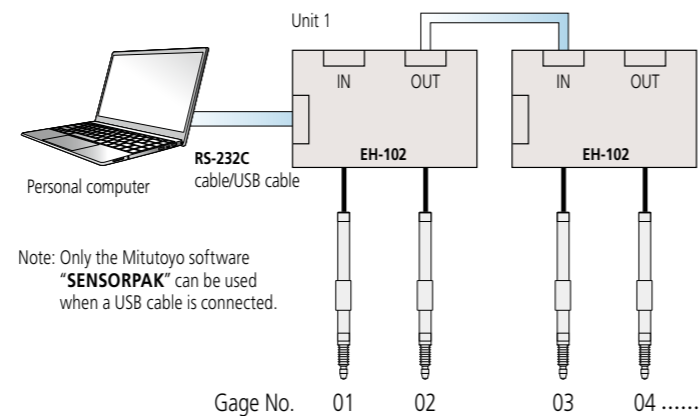

Note: Only the Mitutoyo software "SENSORPAK" can be used when a USB cable is connected.

RS-232C Communication Functions

Makes it possible not only to log measured values but also make various remote settings including the zero-setting of a counter, etc. To communicate data with a PC, terminal software is needed that should be provided by the customer.

Command format	Corresponding output	Function
GA**CRLF	G#** +01234.567CRLF	Outputs the [Displayed value] through RS-232C
CN**CRLF	CH**CRLF	Switches the display to the [Current value]
CX**CRLF	CH**CRLF	Switches the display to the [Maximum value]
CM**CRLF	CH**CRLF	Switches the display to the [Minimum value]
CW**CRLF	CH**CRLF	Switches the display to the [TIR (runout)]
CR**CRLF	CH**CRLF	Zerose
CL**CRLF	CH**CRLF	Clears the peak value
CP** +01234567CRLF	CH**CRLF	Inputs the preset value
CD** +01234567CRLF	CH**CRLF	Inputs tolerance value S1
CE** +01234567CRLF	CH**CRLF	Inputs tolerance value S2
CF** +01234567CRLF	CH**CRLF	Inputs tolerance value S3
CG** +01234567CRLF	CH**CRLF	Inputs tolerance value S4
CS**CRLF	CH**CRLF	Cancel the error
CK**CRLF	CH**,\$CRLF (\$=0 or 1)	Checks the HOLD status

** : denotes a gage channel number between 01 and 99 ("00" means all channels).
 # : denotes the type of data [N: Current value, X: Maximum value, M: Minimum value, W: TIR (runout)].
 CRLF: CR (carriage return), LF (line feed).
 Note 1: For presetting and tolerance limit setting, enter each value consisting of a sign and 8 digits of numeric value without a decimal point.
 Note 2: Perform the tolerance limit setting in the order of CD and CG for the case of 3-step tolerance judgment, and in the order of CD, CE, CF, and CG for the case of 5-step tolerance judgment.
 Note 3: The RS communication function will be suspended during key operation (e.g. setting parameters, preset values, or tolerance limits). It automatically resumes the command and data output operation when the gage is recovered to such a condition that the counting is possible.
 Note 4: For canceling the counting-standby state, use CS00CRLF (specification of all channels).

RS-232C specifications

1) Compatible plug: D-sub9 pin (female), inch thread specification

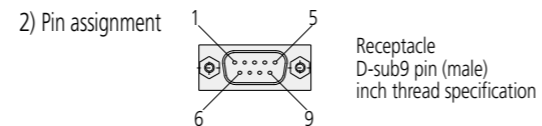

Pin No.	Description	I/O	Function
2	RXD	IN	Receive data
3	TXD	OUT	Send data
4	DTR	OUT	Data terminal ready
5	GND	—	Ground
6	DSR	IN	Data set ready
7	RTS	OUT	Request to send
8	CTS	IN	Clear to send
1, 9	N.C.	—	Connection impossible

3) Communication specifications (conforming to EIA RS-232C)

Home position	DTE (Data Terminal Equipment) Use a cross-type cable.
Communication method	Half-duplex, teletype protocol
Data transfer rate	4800, 9600, 19200 bps
Bit configuration	Start bit: 1 Data bits: (7, 8) ASCII, upper-case characters Number of parity bits: None, even, odd Number of stop bits: 2
Setting the communication conditions	Set via parameters.

Counter Specifications

Standard Accessories

Order No.	Part name	No. of pcs.
—	Washer (small-round, plain washer: nominal 4)	6
357651	AC adapter	1
02ZAA000	AC cord	1
—	DC plug	1
214938	Stand	1
—	Rubber foot (SJ-5303: 3M)	4
99MBC018	User's Guide	1

Optional Accessories

I/O connector

Plus for external I/O receptacle

02ADB440 (with cover)



Connecting cable for Digimatic Mini-processor

Outputs measurement data from a counter to Digimatic Mini-processor

DP-1VA LOGGER.

936937 (1 m)

965014 (2 m)



Connecting cable for "RS link"

This cable is to serially connect a counter during use of "RS link".

02ADD950 (0.5 m)

936937 (1 m)

965014 (2 m)

Input/output specifications

I/O connector pin assignment

1) Suitable plug: **02ADB440** (with cover) Optional accessory

2) Pin assignment

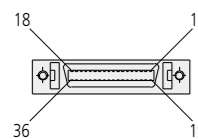

Socket:
10236-52A2
(3M) equivalent

Suitable plug
10136-3000PE (3M: Plug)
10336-52A0-008 (3M: Cover)
DX40M-36P (HIROSE: Plug)
DX30M-36-CV (HIROSE: Cover)

Pin No.	I/O	Description	Tolerance judgment output mode		BCD output mode	
			Function	Description	Function	Description
1, 2	—	COM	Internally connected to GND	COM	Internally connected to GND	
3	O	AL1	[A] Upper row tolerance · Output "L" only for output-relevant terminal · When any error is displayed, AL1, AL5="L" AL2, AL3, AL4="H"	A_bit0 A_bit1 A_bit2 A_bit3 A_SIGN	[A] Upper row data	
4	O	AL2				
5	O	AL3				
6	O	AL4				
7	O	AL5				
8	I/O	ALLGO	Total tolerance result output "H"=OK "L"=NG	READY	"L"=data is valid	
9	O	RS_EXT				
10	O	NOM	Normal output "L"=Normal output, "H"=abnormal output			
11	O	BL1	[B] Lower row tolerance · Output "L" only for output-relevant terminal · When any error is displayed, BL1, BL5="L" BL2, BL3, BL4="H" [2-axis model]	B_bit1 B_bit2 B_bit3 B_SIGN	[B] Lower row data [2-axis model]	
12	O	BL2				
13	O	BL3				
14	O	BL4				
15	O	BL5				
16 to 21			Not connected			
22	O	A_ANG	A-ch analog output			
23	O	B_ANG	B-ch analog output [2-axis model]			
24	—	AGND	Analog GND			
25	I	SET1	Enter the setting value with SET in advance, and determine it with MODE and DISP			
26	I	SET2				
27	I	SET3				
28	I	DISP				
29	I	MODE	Switching of peak value: Combined operation with SET			
30	I	BCDCK	Specifies the BCD output: Combined operation with SET			
31	I	EXTTRG	USB trigger			
32	I	A_HOLD	[A] ch HOLD (Upper row display HOLD)*1			
33	I	B_HOLD	[B] ch HOLD (Lower row display HOLD)*1 [2-axis model]			
34	I	HOLD	HOLD/Error canceling error input*2			
35	I	PA	[A] Upper row preset/Peak clear (in the peak HOLD mode)			
36	I	PB	[B] Lower row preset/Peak clear (in the peak HOLD mode) [2-axis model]			

*1 During input the decimal point will be flashing.

*2 During input the UNIT indicator will be flashing.

3) I/O circuit

1. Output circuit:

NOM, AL1 to AL5, BL1 to BL5 Transistor is "ON" to drive the line to "L" (open-collector output).

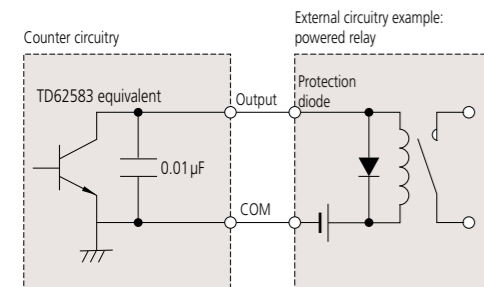

Supply voltage: Max. 24 V
Output current: Max. 10 mA
Output saturation voltage: Max. 0.7 V

2. Input circuit:

PA, PB (only with **542-062**), HOLD Input is valid when the line is "L".

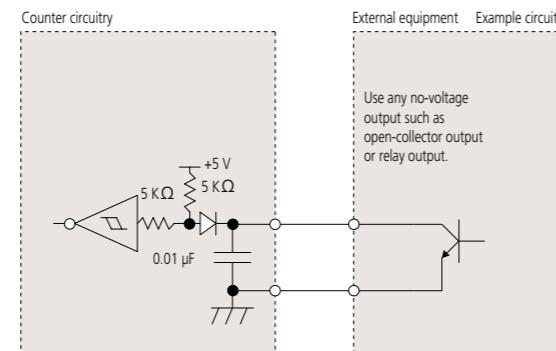

Input current: I_{MAX} 1 mA
Input voltage: H=4 to 24 V
L=Max. 1 V

Output saturation voltage: Max. 0.7 V or less

4) Timing chart

1. Power ON characteristics

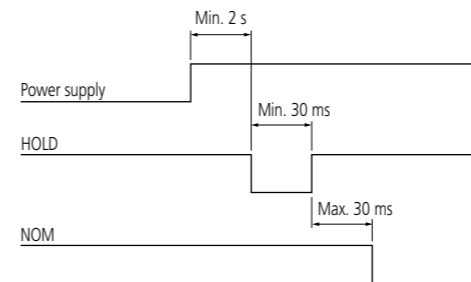

Note: With the RS link established the reference counter will be the one that was powered on last.

3. External preset (PA, PB) input

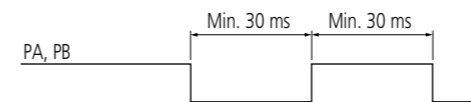

Note: Excluding the period during key input, RS-232C communication or Digimatic processing.

5. RS-232C command input and response output

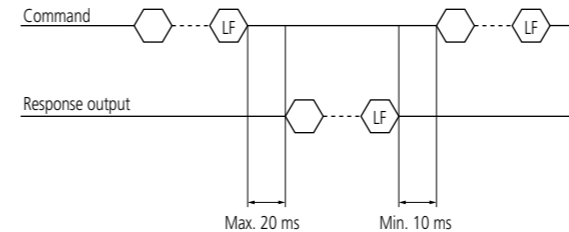

Note: Excluding the period during key input, RS-232C communication or Digimatic processing.

2. Tolerance judgment result output period

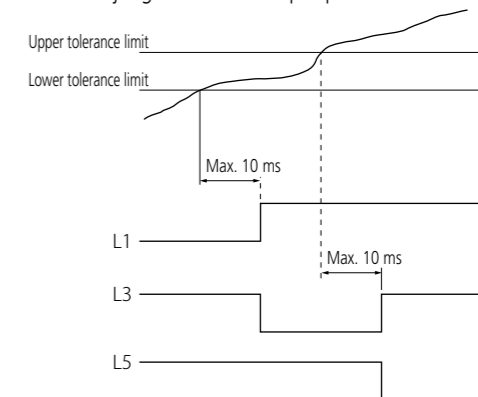

4. Peak clear input

(After inputting HOLD, or simultaneous input with the preset value)

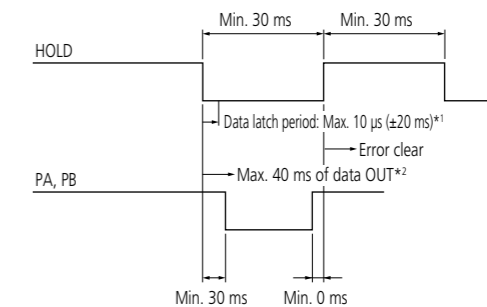

*1 () represents the case either in peak mode or in such a mode that an input of HOLD triggers RS-232C output.

*2 Case in such a the mode that input of HOLD triggers RS-232C output.

Note: The PRESET indicator will be flashing during the input operation of HOLD.

Counter Specifications

Origin Point Mark Detection (EH-102Z, EJ-102N)

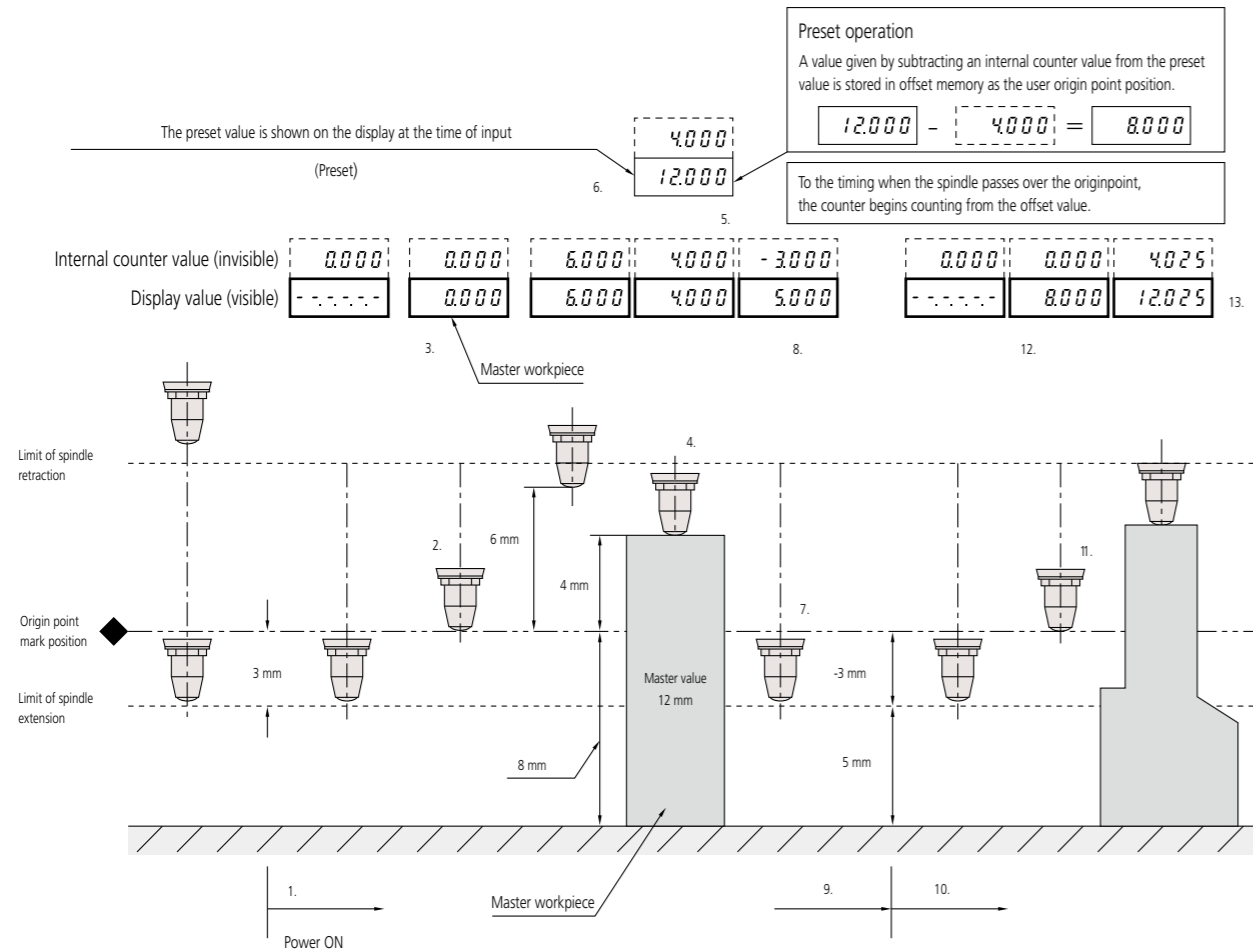

Note: The linear gage used in the above example is the **LG100**, which has a measuring range of 10 mm. This linear gage has its origin point marked at a position approximately 3 mm from the limit of the spindle extension. In the case of 25/50 mm-stroke types the origin point mark is positioned approximately 5 mm from the spindle extension limit.

Origin Point Mark Detection Procedure

1. Turn the display unit connected to the gage head to ON. (The offset register is set to zero at this stage.)
2. Displace the gage head spindle approximately more than 3 mm from the spindle extension limit position to make it pass over the origin point mark.
3. The display unit will automatically read the origin point and zero-set itself.
4. Bring the gage head contact point into contact with the master gage as shown.
5. The display unit indicates the displacement from the origin point position. (Offset register still contains zero.)
6. Input the preset value (the calibrated size of the master gage, 12.000).
7. Remove the master gage so that the spindle extends to its limit.
8. The display unit displays position of the contact point relative to the datum surface.
9. Turn OFF the display unit.
10. Turn ON the display unit.
11. Displace the gage head spindle approximately more than 3 mm from the spindle extension limit position to make it pass over the origin point mark.
12. The display unit will automatically read the origin point and the displayed value will effectively start from the stored offset register value (0.000+8.000=8.000).
13. The contact tip can now be brought into contact with the workpiece to make the measurement and the display will indicate the workpiece size (4.025+8.000=12.025).

Head Specifications

Connecting linear gages to counters / Comparative table of counter functions

Linear gage counter	EC		EH			EJ
	EC-101D	EH-101P	EH-102P	EH-102Z	EH-102D	EJ-102N
Applicable gages	Digimatic	Phase AB	Phase AB	Phase AB	Digimatic	Phase AB
0.1 μm LG100/LG200		✓*5	✓*5	✓*6		✓
0.01 mm LGS	✓				✓	
Functions						
Number of connectable gages	1	1	2	2	2	2
Display	✓	✓	✓	✓	✓	✓
Zero set	✓	✓	✓	✓	✓	✓
Presetting	✓	✓	✓	✓	✓	✓
Direction switch	○	○	○	○	○	○
GO/NG indication	○	✓	✓	✓	✓	✓
GO/NG output	○	✓	✓	✓	✓	✓
5-stage tolerance display/output		○	○	○	○	○
3-stage tolerance display/output	○	○	○	○	○	○
mm/inch switch	✓	✓	✓	✓	✓	✓
ABS gage zero set	✓				✓	
ABS/INC gage changeover	○				○	
Peak (max./min.) hold		✓	✓	✓	✓	✓
Run out (TIR) measurement		✓	✓	✓	✓	✓
Double count	○	○	○	○	○	○
Sum/difference calculation		○	○	○	○	○
Lower digit blank-out		○	○	○	○	○
External zero set	*1	✓	✓	✓	✓	✓
External preset	✓	✓	✓	✓	✓	✓
External hold	✓	✓	✓	✓	✓	✓
External tolerance set (when a PC is used)		✓	✓	✓	✓	✓
External tolerance memory switch (when I/O is used)		✓	✓	✓	✓	✓
External peak-hold cancel		✓	✓	✓	✓	✓
Output						
Power-supply voltage error	✓	✓	✓	✓	✓	✓
Overspeed error	✓	✓	✓	✓	✓	✓
Overflow error	✓	✓	✓	✓	✓	✓
Gage error	✓	✓	✓	✓	✓	✓
Tolerance setting error	✓	✓	✓	✓	✓	✓
Communication error		✓	✓	✓	✓	✓
Parallel BCD output						
Serial BCD output						
Simple BCD output		○	○	○	○	
Simple analog output		✓	✓	✓	✓	
Tolerance judgment output	*2	○	○	○	○	○
Limit output						
Segment output						
RS-232C output		*2	*2	*2	*2	
Digimatic output	*4	*3	*3	*3	*3	
USB output for SENSORPAK		✓	✓	✓	✓	
RS link		*2	*2	*2	*2	
RS link (maximum number of gages)		10	20	20	20	16
CC-Link communication						*7
PROFINET communication						*7
EtherNet/IP communication						*7
EtherCAT communication						*7
USB communication						*7

✓ Standard function ○ Configurable with internal parameters
 *1 Enabled by setting "0" via external presetting. *2 Switchable between the Digimatic output. *3 Switchable between the RS-232C output.
 *4 Switchable between the tolerance judgment output. *5 A conversion plug **21HZA195** is required. *6 A conversion plug **21HZA196** is required. *7 Compatible Interface Unit is required.

SENSORPAK

Measurement data acquisition software for EH, VL



Data Management Software by Mitutoyo

- This software facilitates loading measurement data onto a personal computer from a linear gage counter with RS-232C output (EH), or from a Litematic display (VL).
- 20 channels (max.) of measurement data can be processed.
- Arithmetical calculations and maximum width calculations can be performed using the measurement data.
- Exporting measurement data into MS-Excel format is supported.
- Real time graphical display by means of bar-graph or meter is provided.



Measurement screen 1



Meter screen 2



Chart screen 3



SPECIFICATIONS

SEONSORPAK	
Product configuration	Program disk (CD-ROM), license key, operation manual
Compatible devices	Mitutoyo RS_LINK compatible devices • LGH Series (USB, RS-232C) • EH counter (USB, RS-232C) • Litematic VL (RS-232C)
Connecting cable	A cable should be prepared to the following specifications: Accessory • RS-232C connection: I/O cable (21HZA137)*1 Commercial product • USB connection: USB cable (type A - type B) • RS-232C connection: RS-232C cross cable*1
Number of connectable gages	Max. 20 units (when 10 units of EH counter for linear gage are connected via RS-Link)
Display*2	Display format: counting, bar graph, indicator, chart, and table Display cycle: 0.3 s (when 20 gage units are connected, 1-window display, and no Excel output)
Calculation	Calculation (up to 30 items) between designated gages is available. Calculation items: Sum, difference, total, average, maximum, minimum, range (maximum-minimum), calculation with a constant
Tolerance judgment	Per item: Displays the result in colors (3-step tolerance: red/green/red; 5-step tolerance: red/yellow/green/yellow/red) Total judgment: Displays in colors (red/green) by monitoring the multiple gages and calculation result
Recording*2	Items: channel values, calculation result, tolerance judgment, total tolerance judgment, timestamp Max. number of records: 60000 for software recording (with 6 gages connected); up to 27000 (with 20 gages connected) Output function: Direct output to Excel, CSV file output (compatible with MeasurLink®) Recording trigger: key, timer, external TRG
Input/output*3	Input: TRG for recoderding (HOLD) Output: Total tolerance judgment result
System environment	DOS/V compatible PC environment CPU: Pentium4 2 GHz or more, Memory: 2 GB or more, Hard disk: 2 GB or more free space OS: Windows 7 (32 bit/64 bit), Windows 8.1 (32 bit/64 bit), Windows 10 (64 bit)

*1 If the PC is not equipped with an RS-232C port, please contact the nearest Mitutoyo sales office/service center.
 *2 Display cycle and the maximum number of records differ depending on the environment (specification of PC, number of connected gages, display format and communication setting).
 *3 With use of the I/O cable (accessory). When an I/O cable is not used, the I/O connector of connector of the counter alternatively functions.
 (Refer to the user's manual of the counter in use.)

Linear Gage Accessories (Optional)

Optional gage head accessories

Various Contact Points/Extension Rods (Interchangeable dial indicator contact points are also available.)

- All threads of interchangeable contact points are M2.5 (P=0.45) x5 mm.
- If any contact point is replaced with another, firmly attach it so that it cannot become loosened during use. (Recommended tightening torque=50 N·cm)
- A carbide contact point is particularly good at resisting to abrasion.

ø3 mm Ball Points

Standard contact point. Without groove. Unit: mm

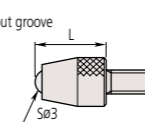

L (mm)	Material	Carbide	Carbide	Plastic
7.3	Order No.	901312	120047	901994
14	Order No.	21JAA225	—	—
15	Order No.	120049	120051	—
17	Order No.	21JAA224	—	—
20	Order No.	137391	137392	—
22	Order No.	21JAA226	—	—
25	Order No.	120053	120055	—
30	Order No.	21AAA252	21AAA253	—

Flat Points

Convenient to use if the feature to be measured is convex. Unit: mm

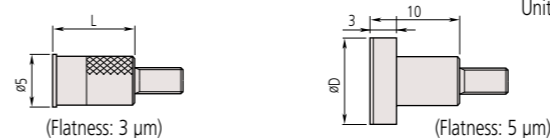

L	Order No.	D	Order No.
8	131365	10	101117
10	21AAA340	15	21AAA341
		20	21AAA342
		25	21AAA343
		30	21AAA344

Note: If perpendicularity to the stem and parallelism with the reference plane are required using a flat contact point, extra adjustment in conjunction with the linear gage is necessary. Consult with Mitutoyo as a custom-made option.

Shell Type Points

Contact point with a large radius. Optimal for use on flat surfaces. Unit: mm

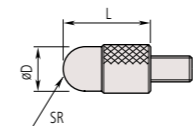

øD	SR	L	Order No.
5	2.5	5	101386
		10	101118
		15	137393
		20	101387
		25	101388
		30	21AAA254

Ball Points

Convenient to measure a depressed feature on a workpiece. Unit: mm

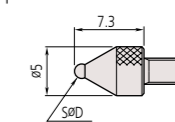

Material: Hardened steel

SR	Spherical tip material	Order No.
1	Carbide	21AAA349
1.5		21AAA350
1.8	Hardened steel	101122
2.5	Carbide	21AAA351
4		21AAA352

Spherical Points

Convenient to use if the feature to be measured is concave. Unit: mm

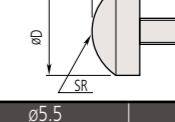

Material: Hardened steel

D	ø5.5	ø8	ø10
SR	5	5	7
L	3	5	5
Order No.	111460	125258	101119

Flat Points (Carbide)

Material: Carbide. Unit: mm

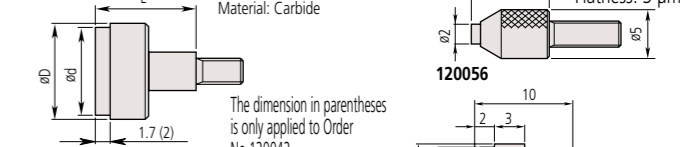

ød	D	L	Flatness	Order No.
4.3	5.2	5	3 µm	120041
6.5	7	5		120042
9.5	10.5	5		120043
15	17	10	5 µm	21AAA345
20	22			21AAA346
25	27			21AAA347
30	32			21AAA348

Note: If perpendicularity to the stem and parallelism with the reference plane are required using a flat contact point, extra adjustment in conjunction with the linear gage is necessary. Consult with Mitutoyo as a custom-made option.

Spherical Points (Carbide)

Material: Carbide (spherical tip surface only). Unit: mm

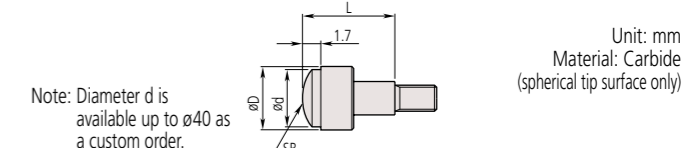

L	D	ø5.2	ø7.5	ø10.5
SR	5	7	10	
5	Order No.	120058	—	—
10	Order No.	—	120059	120060

Note: Diameter d is available up to ø40 as a custom order.

Needle Points

Suitable for probing the bottom of a groove or hole.

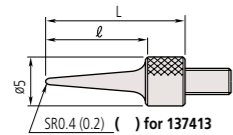

Unit: mm
Material: Hardened steel

Note: Contact Mitutoyo to inquire about specifications such as tip SR: 0.2 or more and l: up to 40.

Order No.	l	L
101121	11	15
137413	13	17
21AAA255	21	25
21AAA256	31	35

Needle Points (Carbide)

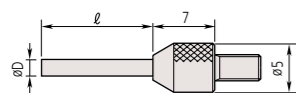

Unit: mm
Material: Carbide

D	l	3	5	8	10	13
ø0.45	Order No.	120066	21AAA329	—	—	—
ø1	Order No.	120065	21AAA330	21AAA331	21AAA332	—
ø1.5	Order No.	—	21AAA335	—	21AAA336	120064
ø2	Order No.	—	—	137257	—	—

D	l	18	20	28	40
ø1	Order No.	—	21AAA333	—	21AAA334
ø1.5	Order No.	—	21AAA337	—	21AAA338
ø2	Order No.	21AAA257	—	21AAA258	21AAA339

Note: A different specification is available as a custom order.

Blade Points (Carbide)

Convenient for cylinder measurement, etc.

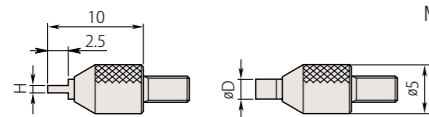

Unit: mm
Material: Carbide

D	H	0.4	0.6	1
ø2	Order No.	120061	120062	—
ø4	Order No.	—	—	120063

Note: If perpendicularity to the stem, parallelism with the reference plane, and different contact point orientation are required using a blade contact point, extra adjustment in conjunction with the linear gage is necessary. Consult with Mitutoyo as a custom-made option.

Conical Points

Used for positioning the measurement point. Since it can damage a workpiece easily, it is not suitable for use on soft materials.

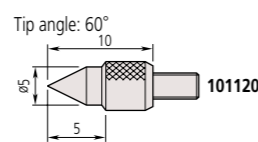

Unit: mm
Material: Hardened steel

90° Conical Points (Carbide)

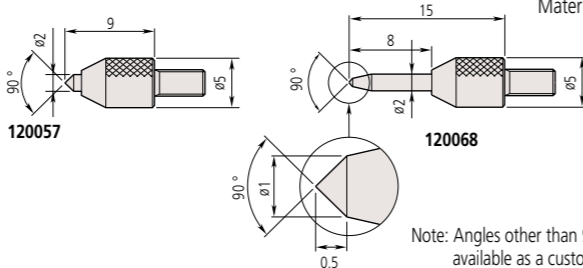

Unit: mm
Material: Carbide

Note: Angles other than 90° are available as a custom order.

Knife Edge Point (Carbide)

Suitable for measuring narrow groove diameter, etc.

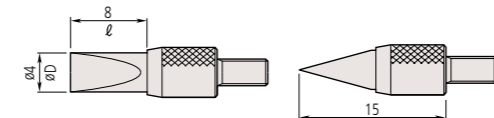

Unit: mm
Material: Carbide

Note: Diameter D more than ø0.5 and length/ between 5 and 40 are available as a custom order.

Extension Rods



Unit: mm
Material: Stainless steel

L	Order No.	L	Order No.
10	303611	55	21AAA259G
15	21AAA259A	60	304146
20	303612	65	21AAA259H
25	21AAA259B	70	21AAA259J
30	303613	75	21AAA259L
35	21AAA259C	80	21AAA259M
40	21AAA259D	90	304147
45	21AAA259E	100	303614
50	21AAA259F	—	—

Roller Points

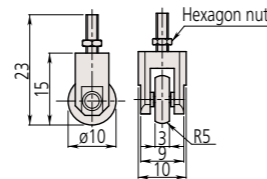

Unit: mm
Roller part material: Hardened steel
Roller run-out: 10 µm

Note 1: A different øD is available as a custom order.
Note 2: A high-accuracy type with a roller run-out of 5 µm is available. (Custom-made option)

Quick Guide to Precision Measuring Instruments

Quick Guide to Precision Measuring Instruments

Gage Head

Plain Stem

The plain stem has the advantage of wider application and slight positional adjustment in the axial direction on final installation, although it does require a split-fixture clamping arrangement or adhesive fixing. However, take care so as not to exert excessive force on the stem.

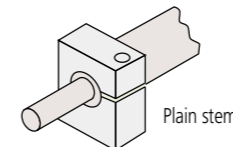

Measuring Force

This is the force exerted on a workpiece during measurement by the contact point of a linear gage head, at its stroke end, expressed in newtons.

Comparative Measurement

A measurement method where a workpiece dimension is found by measuring the difference in size between the workpiece and a master gage representing the nominal workpiece dimension.

Ingress Protection Code

Protection code	Type	Level	Description
IP66	Protection against contact with the human body and foreign objects	6: Dust tight	Protection from dust ingress Complete protection against contact
	Protects against exposure to water	6: Water-resistant type	Water jets directed against the enclosure from any direction shall have no harmful effects.
IP67	Protection against contact with the human body and foreign objects	6: Dust tight	Protection from dust ingress Complete protection against contact
	Protects against exposure to water	7: Immersion-protection	Protection against the effects of immersion in water between 1 cm and 1 m for 30 minutes

Precautions in Mounting a Gage Head

- Insert the stem of the gage into the mounting clamp of a measuring unit or a stand and tighten the clamp screw.
- Notice that excessively tightening the stem can cause problems with spindle operation.
- Never use a mounting method in which the stem is clamped by direct contact with a screw.
- Never mount a linear gage by any part other than the stem.
- Mount the gage head so that it is in line with the intended direction of measurement. Mounting the head at an angle to this direction will cause an error in measurement.
- Exercise care so as not to exert a force on the gage through the cable.

Precautions in Mounting LGH Series

To fix the LGH Series, insert the stem into the dedicated stand or fixture.

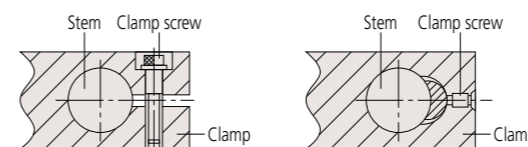

Recommended hole diameter on the fixing side: 15 mm +0.034/+0.014

- Machine the clamping hole so that its axis is parallel with the measuring direction. Mounting the gage at an angle will cause a measuring error.
- When fixing the LGH Series, do not clamp the stem too tightly. Over-tightening the stem may impair the sliding ability of the spindle.
- If measurement is performed while moving the LGH Series, mount it so that the cable will not be strained and no undue force will be exerted on the gage head.

Counter

Zero-setting

The display value can be set to 0 (zero) at any position of the spindle.

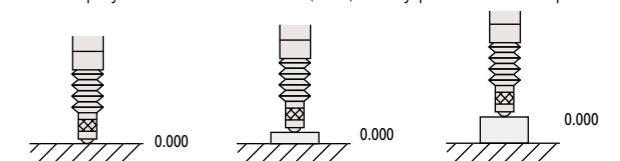

Note: Perform the zero-setting beyond 0.2 mm stroke from the rest position. This puts the spindle in the guaranteed accuracy region.

Presetting

Any numeric value can be set on the display unit for starting the count from this value.



Note: Perform the zero-setting beyond 0.2 mm stroke from the rest position. This puts the spindle in the guaranteed accuracy region.

Direction Changeover

The measuring direction of the gage spindle can be set to either plus (+) or minus (-) of count.

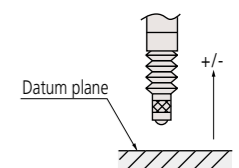

MAX, MIN, TIR Settings

The display unit can hold the maximum (MAX) and minimum (MIN) values, and the run out value (TIR) during measurement.

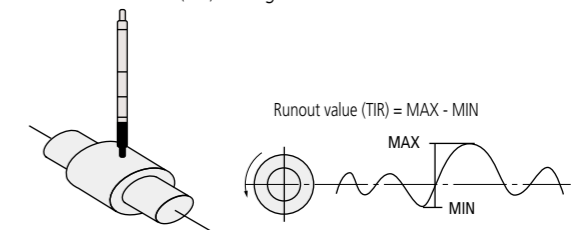

Tolerance Setting

Tolerance limits can be set in various display units for automatically indicating if a measurement falls within those limits.

Open-collector Output

An external load, such as a relay or a logic circuit, can be driven from the collector output of an internal transistor which is itself controlled by a Tolerance Judgment result, etc.

Digimatic Code

A communication protocol for connecting the output of measuring tools with various Mitutoyo data processing units. This allows output connection to a Digimatic Mini-processor DP-1VA LOGGER for performing various statistical calculations and creating histograms, etc.

BCD Output

A system for outputting data in binary-coded decimal notation.

RS-232C Output

A serial communication interface in which data can be transmitted bi-directionally under the EIA Standards. For the transmission procedure, refer to the specifications of each measuring instrument.

CC-Link

An abbreviation of Control & Communication Link, the new open field network developed by Mitsubishi Electric Corporation. It is a high-speed field network that allows for control and communication at the same time.

Before using the gage head

Avoid installing the gage in locations where:

- The gage will be exposed to direct sunlight, or where the ambient temperature may drop below 0 °C or exceed 50 °C*.
- The relative humidity may drop below 20% RH or exceed 80% RH, or where a sudden change in temperature may cause condensation.
- The gage would be subject to corrosive gas, or where combustible materials are placed nearby.
- The gage is subject to air containing significant amounts of dust, salt or iron powder.
- The gage is subject to direct vibration or shock.
- The gage may come in contact with splashed water, oil or chemicals. (The gage system components are not designed for protection against water, oil or chemical attack, except for the gage unit.)
- Electronic noise is likely to affect the gage.

* 0 to 50 °C for LG100 Series, EJ counter and Interface unit

Our Linear gage Series products conform to the EMC Directive and the UK's Electromagnetic Compatibility Regulations.

- EMC Directive/Electromagnetic Compatibility Regulations: EN61326-1

Preventing electrical interference

- Bundling the sensor cable with high-voltage lines or power lines may cause the gage to malfunction. The sensor cable run should be completely separate.

Power supply to the display unit

- If a generic switching regulator is used, provide grounding via the frame's ground terminal or ground terminal of the power supply.
- If a malfunction occurs due to superimposed noise on the power-supply line, use a DC-regulated power supply that incorporates an isolation transformer.

About grounding

- Avoid sharing the frame ground (F.G.) terminal of this unit with the high-power line grounding but separately connect it to Class 3 Grounding.

Handling precautions

- This product is a precision measuring instrument. Avoid dropping or otherwise subjecting it to impact.
- The spindle of the gage head is connected to the body via a spring. Be careful not to pull the spindle in the extending direction or rotate it with force. Doing so may cause permanent distortion and damage to the spring.
- The gage is shipped with a standard contact point (901312) installed on the spindle. This contact point can be replaced with a different type that best suits the shape of the workpiece feature to be measured. (See page 52, 53.)
- When installing or removing a contact point, locate the key wrench provided in the wrench groove in order to keep the spindle from rotating. Then grip the contact point with pliers to install or remove it. When gripping the contact point with pliers, insert a piece of felt or other soft packing between the jaws and the point to protect it from damage.
- Do not use both ends of the stroke as an origin (zero) point.

Precautions in mounting a Linear gage

LG100 / LG200 series

The following illustrate important points to which customers should pay attention. Refer to these when using gage heads and counters.

Replacing the contact point

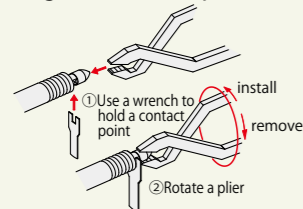

[How to install/remove the contact point]

The contact point is interchangeable according to the application. When installing or removing a contact point, locate the key wrench provided in the wrench groove in order to keep the spindle from rotating. Then grip the contact point with pliers to install or remove it. When gripping the contact point with pliers, insert a piece of felt or other soft packing between the jaws and the point to protect it from damage.

LG100/LG200 Series Mounting the thrust stem

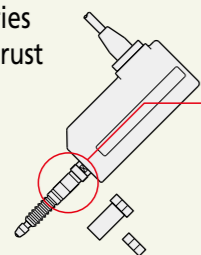

If the thrust stem is retrofitted, the gage can be fixed more steadily and easily only by drilling a $\phi 9.5$ hole on a plate with a thickness of about 10 mm. To mount the thrust stem, fit the special wrench (optional) in the wrench groove in the middle of the main unit, and then fasten the clamp nut with the standard-supplied wrench while holding the knurled part by hand. Take care not to hold the cable receptacle on the main unit, otherwise the gage may be damaged due to torque caused by twisting.

Note 1 Refer to page 21.

Precautions in mounting a Linear gage

LGH Type

Mounting the gage

A LGH can be mounted by inserting its stem in the mounting hole of a dedicated stand or other equipment.

Recommended mounting hole diameter in fixture: $15\text{ mm } \begin{matrix} +0.024 \\ +0.006 \end{matrix}$

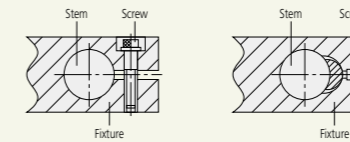

- The mounting hole shall be machined parallel with the direction of measurement. Cosine-effect measurement error will occur if the gage is misaligned with this direction.
- Excessive force in tightening the stem will affect smooth spindle motion and should be avoided.
- In applications where a LGH is subject to movement, ensure that the mounting is designed to avoid the cable being dragged when in motion.

Precautions for measurement:

- To help ensure accuracy, allow 30 minutes warm-up time for the system after powering ON.
- Allow sufficient time for temperature stabilization for both the gage and workpieces to be measured.
- Thoroughly clean the contact point and all surfaces to be measured before measurement to avoid accuracy degradation due to dust or grease.
- Be aware of possible overspeed errors if the contact point is allowed to drop significantly from surface to surface on the workpiece. Appropriate measuring procedures should always be used with due consideration for the part features.

Applies to all linear gages

Mounting the gage head

- Insert the stem of the gage into the mounting clamp of a measuring unit or a stand and tighten the clamp screw.
- Notice that excessively tightening the stem can cause problems with spindle operation.
- Never use a mounting method in which the stem is clamped by direct contact with a screw.
- Never mount a linear gage by any part other than the stem.
- Mount the gage head so that it is in line with the intended direction of measurement. Mounting the head at an angle to this direction will cause an error in measurement.
- Exercise care so as not to exert a force on the gage through the cable.

Examples of the plain-stem mount

- The recommended clamping torque is 0.4 to 0.5 Nm. Over-tightening the stem clamp will prevent smooth movement of the spindle. Ensure the spindle can move freely after clamping.

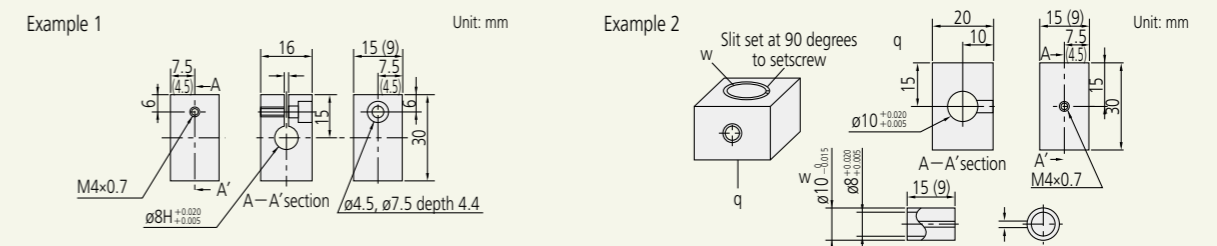

About dust/water protection

- The preamplifiers and counters are not designed to be dust- or water-proof. Install them in places where they will not come into direct contact with dust, water or oil.
- When an extension cable is used, seal the preamplifier connection and connectors completely, making sure no portion is left exposed.
- If the cable cover is damaged, water or other liquids may enter the gage due to capillary effect, causing gage failure. If the cable cover becomes damaged it should be repaired or replaced immediately.
- Handle the gage with due caution to make sure that the rubber boot will not be damaged by scuffing, etc. If the rubber boot is damaged, the gage can no longer be protected from dust or water ingress. When damage is found, repair or replace the boots immediately.
- The rubber material used for the boots and seals does not provide complete protection against coolants and chemicals, which are becoming increasingly complex in composition. If rubber parts are found to have deteriorated significantly, contact your nearest Mitutoyo office.
- The gage must not be disassembled, since it will break the seals of various components. Never attempt to disassemble the gage. Doing so will prevent the gage from functioning to its original specifications.



**Whatever your challenges are,
Mitutoyo supports you from start to finish.**

Mitutoyo is not only a manufacturer of top quality measuring products but one that also offers qualified support for the lifetime of the equipment, backed up by comprehensive services that ensure your staff can make the very best use of the investment.

Apart from the basics of calibration and repair, Mitutoyo offers product and metrology training, as well as IT support for the sophisticated software used in modern measuring technology. We can also design, build, test and deliver measuring solutions and even, if deemed cost-effective, take your critical measurement challenges in-house on a sub-contract basis.



**Find additional product literature
and our product catalogue**

<https://www.mitutoyo.co.jp/global.html>

Our products are classified as regulated items under Japanese Foreign Exchange and Foreign Trade Law. Please consult us in advance if you wish to export our products to any other country. If the purchased product is exported, even though it is not a regulated item (Catch-All controls item), the customer service available for that product may be affected. If you have any questions, please consult your local Mitutoyo sales office.

Note: Product illustrations are without obligation. Product descriptions, in particular any and all technical specifications, are only binding when explicitly agreed upon.
MITUTOYO and MICAT are either registered trademarks or trademarks of Mitutoyo Corp. in Japan and/or other countries/regions. Other product, company and brand names mentioned herein are for identification purposes only and may be the trademarks of their respective holders.

Mitutoyo

Mitutoyo Corporation

20-1, Sakado 1-Chome,
Takatsu-ku, Kawasaki-shi,
Kanagawa 213-8533, Japan
T +81 (0) 44 813-8230
F +81 (0) 44 813-8231
<https://www.mitutoyo.co.jp>