



Assembly Type ABSOLUTE Linear Scale

ABS AT1300 SERIES

User's Manual - Instructions for use -

Read this User's Manual thoroughly before operating the instrument. After reading, retain it close at hand for future reference.

This English language version of the User's Manual contains the original instructions.

No. 99MBE097B1

Date of publication: August 1, 2021 (1)



■ Correspondence of product names and model numbers

Product name	Model number
Assembly Type ABSOLUTE Linear Scale	ABS AT134* ABS AT135* ABS AT138*A ABS AT130*A

■ Notice regarding this guide





- Mitutoyo Corporation assumes no responsibilities for any damage to the instrument, caused by its use not conforming to the procedure described in this User's Manual.
- Upon loan or transfer of this instrument, be sure to attach this User's Manual to the instrument.
- In the event of loss or damage to this manual, immediately contact the agent where you purchased the product or a Mitutoyo sales office.
- Before operation of the instrument, thoroughly read this manual to comprehend its contents.
- Particularly, for full understanding of information, carefully read "Safety Precautions" and "Precautions for Use" at the outset of this manual before using the instrument.
- The contents in this manual are based on the information current as of August, 2021.
- No part or whole of this manual may be transmitted or reproduced by any means without prior written permission of Mitutoyo Corporation.
- Some screen displays in this manual may be highlighted, simplified or partially omitted for convenience of explanation. In addition, some of them may differ from actual ones to the extent that no user will misunderstand the functions and operations.
- The corporation, organization and product names that appear in this manual are their trademarks or registered trademarks.

©2018-2021 Mitutoyo Corporation. All rights reserved.



CONVENTIONS USED IN MANUALS

Conventions used in Mitutoyo's User's Manual are roughly divided into three types (safety reminders, prohibited and mandatory actions, and referential information and locations). Moreover, these conventions include general warnings and specific warnings. Specific warning symbols are provided with concrete pictograms inside of them.

■ Safety reminder conventions and wording warning against potential hazards

	Indicates an immediately hazardous situation which, if not avoided, will result in serious injury or death.
	Indicates a potentially hazardous situation which, if not avoided, could result in serious injury or death.
	Indicates a potentially hazardous situation which, if not avoided, may result in minor injury.
	Indicates a potentially hazardous situation which, if not avoided, may result in property damage.
	Alerts the user to a specific hazardous situation that means "Caution, risk of electric shock".

■ Conventions and wording indicating prohibited and mandatory actions

	Indicates concrete information about prohibited actions.
	Indicates concrete information about mandatory actions.
	Indicates that grounding needs to be implemented.

■ Conventions and wording indicating referential information or referential locations

Tips Indicates referential information such as that for when the operating methods and procedures which are printed in these sentences are to be applied to specific conditions.



Indicates referential locations if there is information that should be referred to in this document or an extraneous manual.

E.g.: For further details on, refer to  "1.2 Name and Functions of Each Part" on page 2.

Safety Precautions

Read these Safety Precautions thoroughly before operating the system to use it properly.

These safety precautions include such information as to prevent an injury to the operator and other persons or damage to property. Be sure to observe the precautions.

NOTICE

- Read this User's Manual thoroughly before operating this product.
- Before connecting this product to the machine main unit, make sure that the power for the control unit is turned off.
- To maintain the shielding effect, firmly tighten the screws on the connectors of each connecting cable.
- To prevent defective contacts, do not touch the connecting terminals of the connectors with bare hands.

Electromagnetic Compatibility (EMC)

This product complies with the EMC Directive and the UK Electromagnetic Compatibility Regulations; however, if this receives electromagnetic interference that exceeds these requirements, it will be out of warranty and require appropriate measures.

This product is an industrial product, and is not intended to be used in residential environment. If this product is used in residential environment, this product may cause electromagnetic interference with other instruments. In such a case, it is required to take appropriate measures for preventing such electromagnetic interference.

Required Environment for Installation

■ Vibration

To install this product onto a machine main unit, select a location where there is as little vibration as possible.

If the scale unit is used for an extended period of time on a machine where there is a substantial amount of vibration, the built-in precision parts may be damaged, thereby adversely influencing the performance of the unit.

■ Shock, dust, water protection

To protect the scale unit from being directly exposed to machining oil and chips, or from being bumped by a workpiece, etc., prepare a cover that protects the entire unit.

■ Ambient temperature and humidity

This product should be operated in an environment where the temperature is 0 °C–50 °C and where the relative humidity is between 20 %–80 %RH. Do not use this product in a place where sudden changes in temperature or humidity are observed.

Export Control Compliance

This product falls into the Catch-All-Controlled Goods and/or Catch-All-Controlled Technologies (including Programs) under Category 16 of Appended Table 1 of the Export Trade Control Order or under Category 16 of the Appended Table of Foreign Exchange Control Order, based on the Foreign Exchange and Foreign Trade Act of Japan.

If you intend re-export of the product from a country other than Japan, re-sale of the product in a country other than Japan, or re-provision of the technology (including program), you are obligated to observe the regulations of your country.

Also, if an option is added or modified to add a function to this product, this product may fall under the category of List-Control Goods and/or List-Control Technology (including Programs) under Category 1 - 15 of Appended Table 1 of the Export Trade Control Order or under Category 1 - 15 of the Appended Table of Foreign Exchange Control Order, based on Foreign Exchange and Foreign Trade Act of Japan. In that case, if you intend re-export of the product from a country other than Japan, re-sale of the product in a country other than Japan, or re-provision of the technology (including program), you are obligated to observe the regulations of your country. Please contact Mitutoyo in advance.

Notes on Export to European Countries

When you intend exporting of this product to any of the European countries, it may be required to provide User's Manual(s) in English and Declaration of Conformity in English (in some cases, the official language of the country to be exported). For detailed information, please contact Mitutoyo in advance.

Disposal of Products outside the European Countries

Please follow the official instruction in each community and country.

Disposal of Old Electrical & Electronic Equipment (Applicable in the European Countries with Separate Collection Systems)



This symbol on the product or on its packaging is based on WEEE Directive (Directive on Waste Electrical and Electronic Equipment), and this symbol indicates that this product shall not be treated as household waste.



To reduce the environmental impact and minimize the volume of landfills, please cooperate in reuse and recycle.

For how to dispose of the product, please contact the agent where you purchased the product or a Mitutoyo sales office.

China RoHS Compliance Information

This product meets China RoHS requirements. See the table below.

产品中有害物质的名称及含量

部件名称	有害物质					
	铅 (Pb)	汞 (Hg)	镉 (Cd)	六价铬 (Cr(VI))	多溴联苯 (PBB)	多溴二苯醚 (PBDE)
本体	○	○	○	○	○	○
电气设备部分	×	○	○	○	○	○
配件	○	○	○	○	○	○

本表格依据 SJ/T 11364 的规定编制。

○: 表示该有害物质在该部件所有均质材料中的含量均在 GB/T 26572 规定的限量要求以下。

×: 表示该有害物质至少在该部件的某一均质材料中的含量超出 GB/T 26572 规定的限量要求。



环保使用期限标识是根据《电器电子产品有害物质限制使用管理办法》以及《电子电气产品有害物质限制使用标识要求(SJ/T11364-2014)》制定的,适用于中国境内销售的电子电气产品的标识。

电器电子产品只要按照安全及使用说明内容在正常使用情况下,从生产日期算起,在此期限内产品中含有的有毒有害物质不致发生外泄或突变,不致对环境造成严重污染或对其人身、财产造成严重损害。

产品使用后,要废弃在环保使用年限内或者刚到年限的产品,请根据国家标准采取适当的方法进行处置。

另外,此期限不同于质量/功能的保证期限。

Warranty

This product has been manufactured under strict quality management, but should it develop problems within one year of the date of purchase in normal use, repair shall be performed free of charge. Please contact the agent where you purchased the product or a Mitutoyo sales office ( "SERVICE NETWORK" on page App-1). This warranty, however, shall not affect any provisions of the Mitutoyo Software End User License Agreement.

If this product fails or is damaged for any of the following reasons, it will be subject to a repair charge, even if it is still under warranty.

- Failure or damage owing to fair wear and tear
- Failure or damage owing to inappropriate handling, maintenance or repair, or to unauthorized modification
- Failure or damage owing to transport, dropping, or relocation of the instrument after purchase
- Failure or damage owing to fire, salt, gas, abnormal voltage, lightning surge, or natural disaster
- Failure or damage owing to use in combination with hardware or software other than those designated or permitted by Mitutoyo
- Failure or damage owing to use in ultra-hazardous activities

This warranty is effective only where the instrument is properly installed and operated in conformance with the instructions in this manual within the original country of the installation.

EXCEPT AS SPECIFIED IN THIS WARRANTY, ALL EXPRESS OR IMPLIED CONDITIONS, REPRESENTATIONS, AND WARRANTIES OF ANY NATURE WHATSOEVER INCLUDING, WITHOUT LIMITATION, ANY IMPLIED WARRANTY OF MERCHANTABILITY, FITNESS FOR A PARTICULAR PURPOSE, NONINFRINGEMENT OR WARRANTY ARISING FROM A COURSE OF DEALING, USAGE, OR TRADE PRACTICE, ARE HEREBY EXCLUDED TO THE MAXIMUM EXTENT ALLOWED BY APPLICABLE LAW.

You assume all responsibility for all results arising out of its selection of this product to achieve its intended results.

Disclaimer

IN NO EVENT WILL MITUTOYO, ITS AFFILIATED AND RELATED COMPANIES AND SUPPLIERS BE LIABLE FOR ANY LOST REVENUE, PROFIT, OR DATA, OR FOR SPECIAL, DIRECT, INDIRECT, CONSEQUENTIAL, INCIDENTAL, OR PUNITIVE DAMAGES HOWEVER CAUSED AND REGARDLESS OF THE THEORY OF LIABILITY ARISING OUT OF THE USE OF OR INABILITY TO USE THIS PRODUCT EVEN IF MITUTOYO OR ITS AFFILIATED AND RELATED COMPANIES AND/OR SUPPLIERS HAVE BEEN ADVISED OF THE POSSIBILITY OF SUCH DAMAGES.

If, notwithstanding the foregoing, Mitutoyo is found to be liable to you for any damage or loss which arises out of or is in any way connected with use of this product by you, in no event shall Mitutoyo's and/or its affiliated and related companies' and suppliers' liability to you, whether in contract, tort (including negligence), or otherwise, exceed the price paid by you for the product only.

The foregoing limitations shall apply even if the above-stated warranty fails in its essential purpose. BECAUSE SOME COUNTRIES, STATES OR JURISDICTIONS DO NOT ALLOW THE EXCLUSION OR THE LIMITATION OF LIABILITY FOR CONSEQUENTIAL OR INCIDENTAL DAMAGES, IN SUCH COUNTRIES, STATES OR JURISDICTIONS, MITUTOYO'S LIABILITY SHALL BE LIMITED TO THE EXTENT PERMITTED BY LAW.

About This Document

■ Positioning of this document in document map

In addition to this document, software-related manuals are available.

● For linear scale

ABS AT1300 Series
User's Manual
(This Document)

● For software

ABS AT1300 Series
Signal Check Program
User's Manual

■ Intended readers and purpose of this document

● Intended readers

This document is intended for beginners of ABS AT 1300 Assembly Type ABSOLUTE Linear Scale. They are also assumed to be able to understand individual instructions by reading screen displays.

● Purpose

This document is aimed at understanding a basic knowledge of ABS AT 1300 Assembly Type ABSOLUTE Linear Scale.

Contents

CONVENTIONS USED IN MANUALS	i
Safety Precautions	ii
Electromagnetic Compatibility (EMC)	ii
Required Environment for Installation	ii
Export Control Compliance	iii
Notes on Export to European Countries	iii
Disposal of Products outside the European Countries	iii
Disposal of Old Electrical & Electronic Equipment (Applicable in the European Countries with Separate Collection Systems)	iii
China RoHS Compliance Information	iv
Warranty	v
Disclaimer	vi
About This Document	vii
Contents	viii
1 Overview	1
1.1 Features	1
1.2 Name and Functions of Each Part	2
1.3 The Flow of Main Tasks	3
2 Setup for Installation	5
2.1 Checking the Equipment Model	5
2.2 Checking the Scale Unit and the Supplied Accessories.....	6
2.3 Preparing the Signal Cable	8
2.3.1 Configuration of the Signal Cable	8
2.3.2 Bend Radius of the Signal Cable	10
2.4 Precautions on Designing Scale Unit Mounting Surface	11
2.4.1 Datum Point Position for the Length Variation and ABS Origin	11
2.4.2 Counting Direction	12
2.4.3 Checking the Maximum Travel Distance and Effective Length	12
2.4.4 Scale Main Unit Mounting Directions and Cover Preparations	13
2.4.5 Precautions on Designing the Mounting Surface	15
3 Installation onto the Machine Main Unit	17

3.1	Procedure for Installation onto the Machine Main Unit	17
3.2	Mounting the Scale Main Unit and Adjusting the Position	17
3.2.1	Checking the Mounting Surface, etc.....	17
3.2.2	Mounting the Scale Main Unit.....	18
3.3	Mounting the Detector and Adjusting the Position	24
3.3.1	Installing the Detector	24
3.4	Connecting and Fixing the Signal Cable	27
3.4.1	Cable Connection and Operation Check	27
3.4.2	Connecting the Signal Cable	28
3.4.3	Precautions on Fixing the Cables	30
4	Specifications	33
4.1	Specifications	33
4.2	Signal Cable Specifications	34
4.2.1	Output Signal	34
4.2.2	Cable Dimensions	36
4.3	System Configuration (Example)	41
4.4	Production of Feedback Cable (Example)	42
4.4.1	Appearance Image of Feedback Cable and Grounding to Ground Bar	42
4.4.2	Assembly of D Sub Connector	42
4.4.3	Calculation of Feedback Cable Length	44
4.4.4	Wiring with NC Device (Example)	46
4.5	Alarm Detection Function	49
4.5.1	Alarm Detection Function	49
4.5.2	Alarm Code Content.....	50
4.6	Air Purging	54
4.6.1	Input Air Specification	54
4.6.2	Air Flow Supplied to the Scale	54
4.6.3	Air Supply Unit	55
4.6.4	Connection Method	57
4.7	External View and Dimensional Drawings of the Scale Main Unit	58
4.7.1	ABS AT1300-H (High Precision Specification).....	58
4.7.2	ABS AT1300-S (High Rigidity Specification)	60
5	Troubleshooting	63
6	Appendix.....	65
6.1	Quantity of the Supplied Accessories for Installation	65
6.1.1	ABS AT1300-H (High Precision Specification).....	65
6.1.2	ABS AT1300-S (High Rigidity Specification)	66

1 Overview

This chapter describes the features of this product, names and functions of each part, and the flow of the main tasks to use this product.

1.1 Features

The linear scale will output a moving amount and displacement as digital amounts based on a linear scale graduated in certain fixed pitches.

This can precisely measure moving amounts of various instruments including electronic/semiconductor manufacturing units and machine tools.

This product adopts an imaging method based on the double-sided telecentric optical system to detect the moving amount of the scale. With this a focal depth and a wide imaging range, this method is less susceptible to scale undulation and dirt, and it has excellent environmental resistance.

Also, this product does not require an origin return step at the starting time of work or during a power failure, and does not require batteries for backup, which will contribute much labor saving.

Moreover, this product can be used in harsh environments where cutting oil or chips occur.

This product has the following two types and specifications with different effective measuring lengths.

Items	High precision specification	High rigidity specification
Features	Since the aluminum frame that fixes the scale main unit is not in contact with the mounting surface of the machine, it has excellent stability in the origin position with respect to temperature change	Since the aluminum frame that fixes the scale main unit is in contact with the mounting surface of the machine, it has excellent vibration resistance or impact resistance
Effective length	100 mm–1000 mm (15 types)	100 mm–2200 mm (19 types)

In addition, the following interface specifications compatible with the high-speed serial interface of the companies are available.

- Mitsubishi Electric Corporation Specifications
- FANAC Corporation Specifications
- YASKAWA Electric Corporation Specifications
- Mitutoyo ENSIS Specifications

1.2 Name and Functions of Each Part

We call this product the "scale unit" generically. The scale unit is composed of the scale main unit and the Detector.

Here, the high rigidity specification is used as an example.

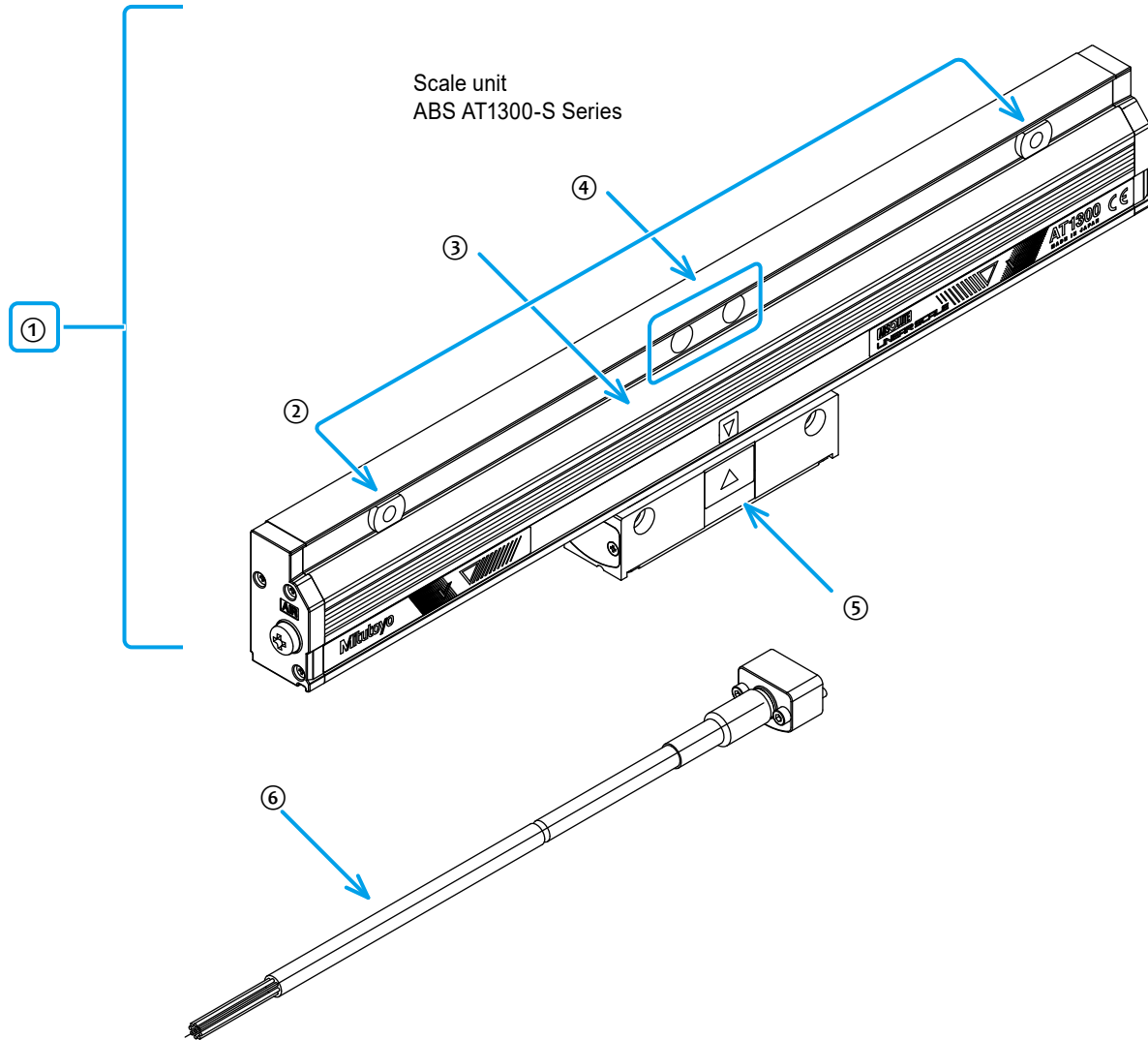

No.	Name	Description
①	Scale unit	The generic name of this product. It indicates the state that the Detector has been mounted on the scale main unit.
②	Elastic-fixing part	The point to be fixed later during installation onto the machine main unit.
③	Scale main unit	It represents the linear scale's main unit.
④	Full-fixing part	The datum position for length variation due to changes in temperature (reference point for the scale's mechanical expansions and contractions due to changes in temperature). The point to be fixed first during installation onto the machine main unit.
⑤	Detector	The part to detect a measurement point.
⑥	Signal cable (option)	The cable to connect this product and the connection destination controller. You can connect the signal cable to either left or right side of the Detector.

1.3 The Flow of Main Tasks

The following chart shows the flow of preliminary preparation and installation onto the machine main unit as tasks to use this product.

■ Preliminary preparation

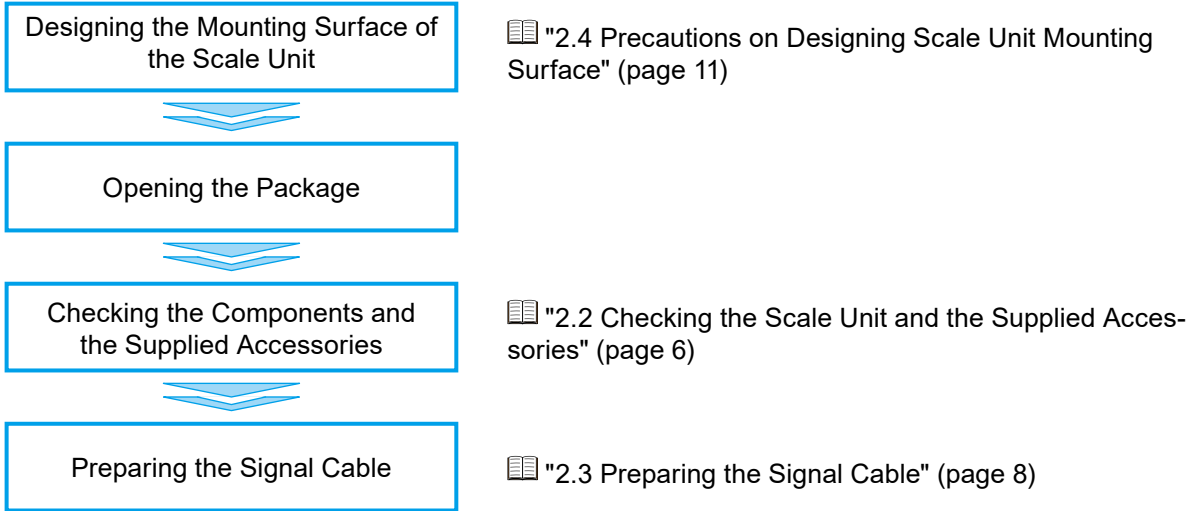

■ Installation onto the machine main unit

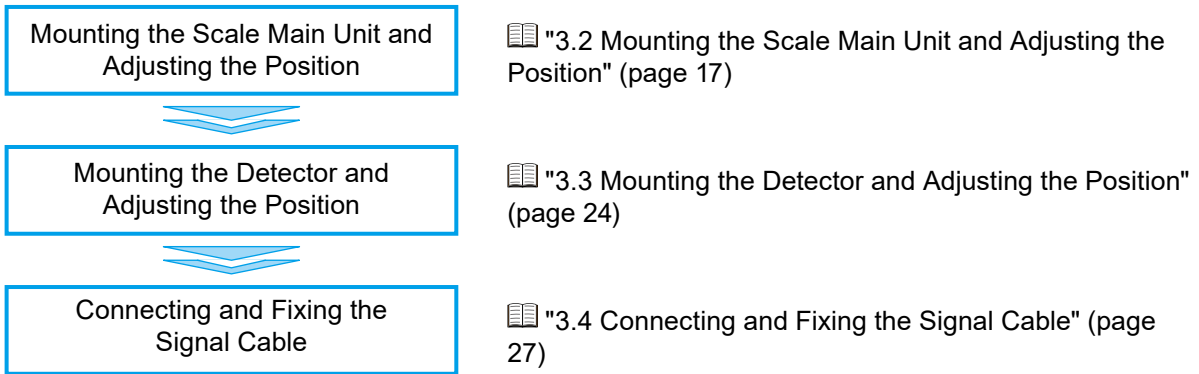

MEMO

2 Setup for Installation

This chapter describes the preliminary preparation for installing this product onto machine main unit.

2.1 Checking the Equipment Model

This document describes the models configured as shown below.

First, be sure to check which model will be used.

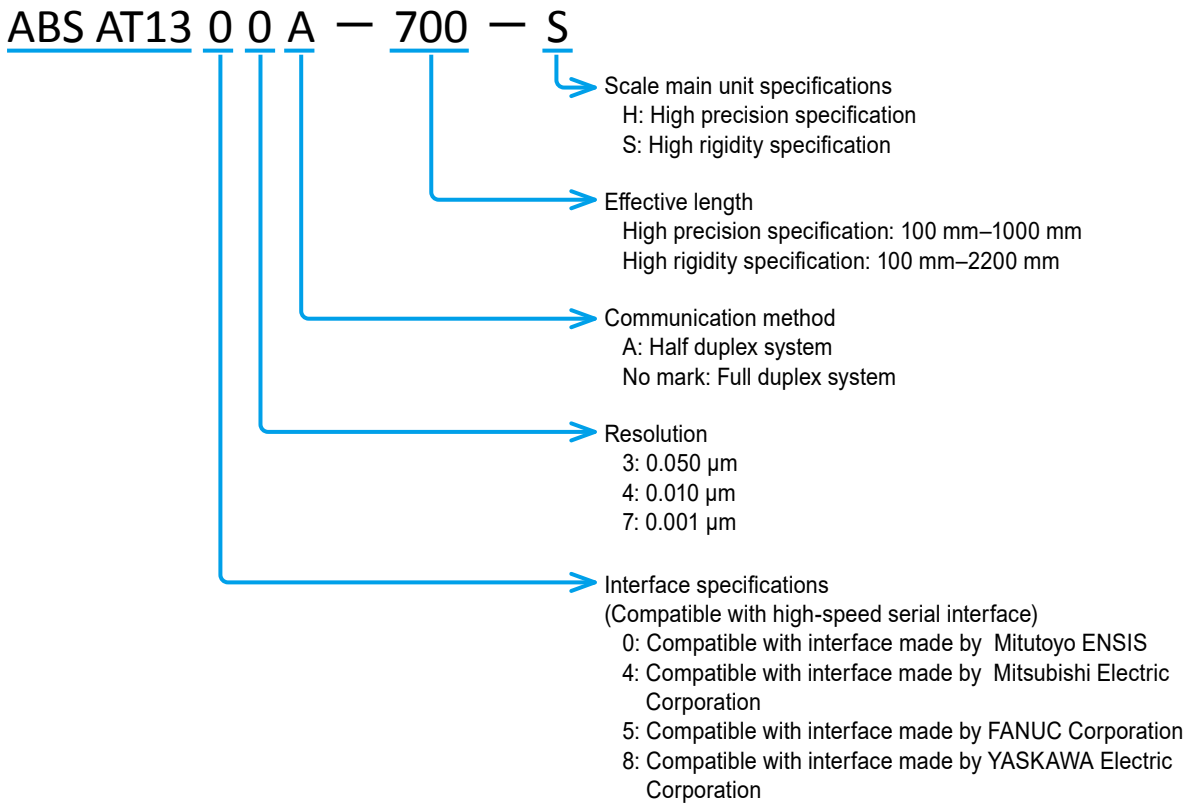

For the details of the effective length, refer to "4 Specifications" (page 33)

2.2 Checking the Scale Unit and the Supplied Accessories

A configuration of this product is shown below.

The accessories of this product are different depending on the specifications of the scale main unit. First, make sure that there are no missing components in the accessories.

Also, check for any damage that may have occurred during transportation.

If you have any questions or concerns about the product, please contact the agent where you purchased the product or a Mitutoyo sales office/service center.

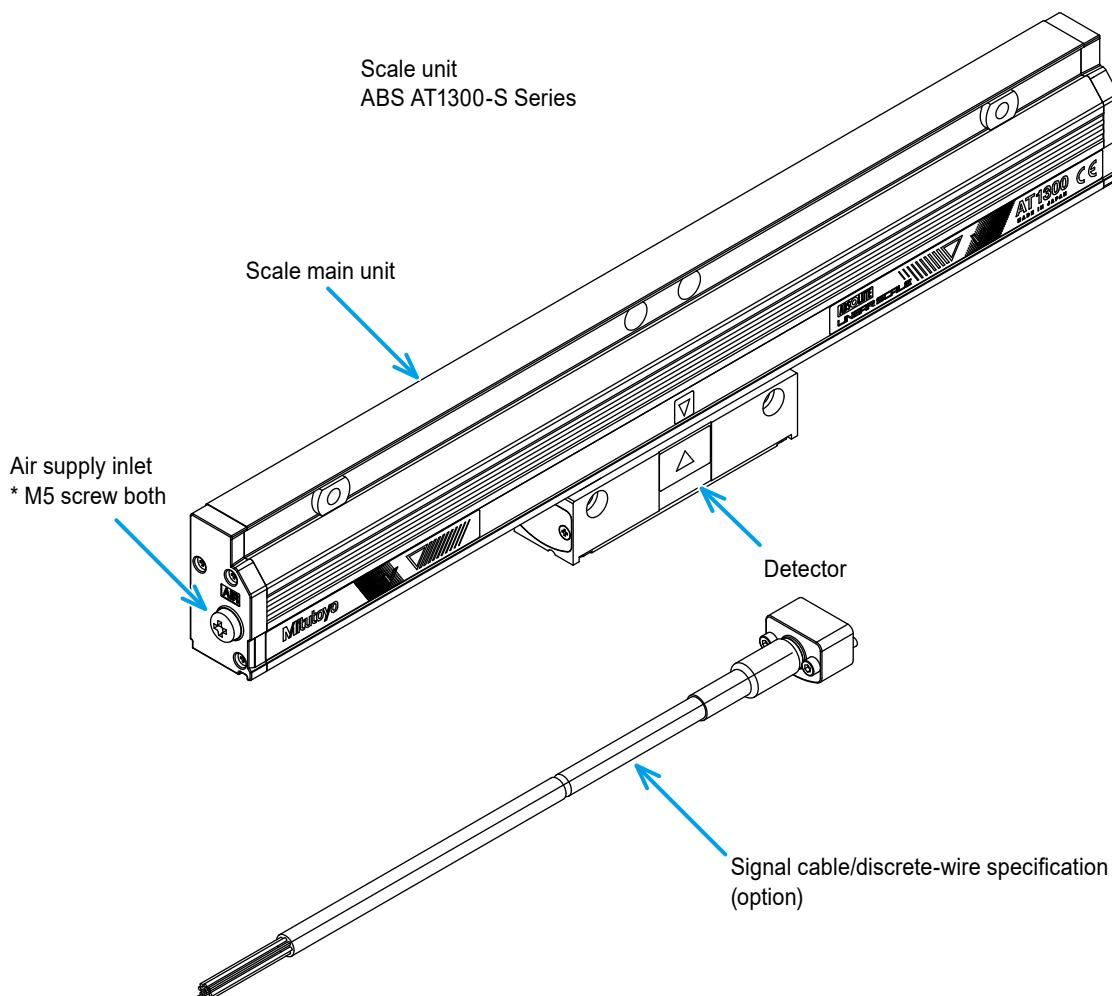

Items	Scale main unit specifications		Note
	H: High precision specification	S: High rigidity specification	
Scale unit	One axis	One axis	
Accessories	Screw set	Leaf spring, screw set	
User's Manual	One (this manual)	One (this manual)	
Warranty card	One copy	One copy	
Inspection certificate	One copy	One copy	

For the details of the signal cable, refer to "2.3 Preparing the Signal Cable" (page 8)

2 Setup for Installation

■ Accessories (mounting screws, etc.)

For the details of the quantity of the accessories, refer to  "6.1 Quantity of the Supplied Accessories for Installation" (page 65)

● ABS AT1300-H (high precision specification)

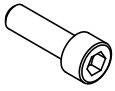

Hex socket head cap
screw
M4 x 10

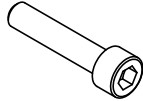

Hex socket head cap
screw
M4 x 16



Spring washer,
nominal 4

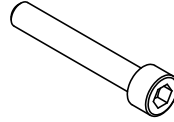

Hex socket head cap
screw
M4 x 25

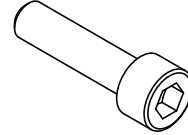

Hex socket head cap
screw
M6 x 25



Spring washer,
nominal 6

● ABS AT1300-S (high rigidity specification)

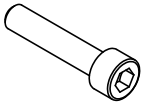

Hex socket head cap
screw
M4 x 16

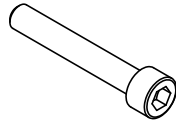

Hex socket head cap
screw
M4 x 25



Spring washer, nominal 4
Small round



Plain washer, nominal 4
Small round

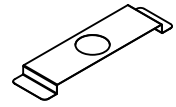

Dedicated leaf spring

2.3 Preparing the Signal Cable

This section describes the configuration of the signal cable to be used with this product.
The signal cables are separately sold. Select an appropriate one according to your specifications.

2.3.1 Configuration of the Signal Cable

Connect the signal cable to the electronic components with one of the connectors provided on either side of the Detector.

For the details of the connecting method, refer to  "3.4 Connecting and Fixing the Signal Cable" (page 27)

For the specifications of the signal cable, select an appropriate cable length and output connector type.

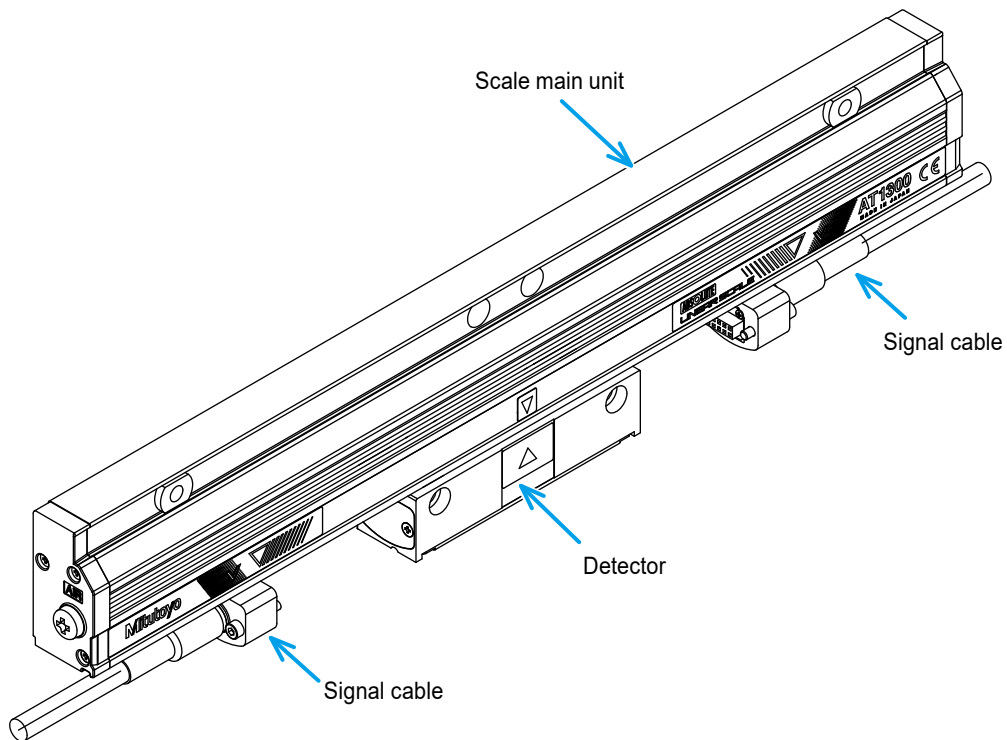

■ Available signal cable (option)

Items	Specifications
Cable length	1 m–9 m (every 1 m) 12 m
Cable material	PVC sheath ø6.5, no conduit
Output connector	(1) Discrete-wire specification (2) Specification with alarm display function (3) FANUC connector specification (4) Mitsubishi connector specification (5) YASKAWA connector specification

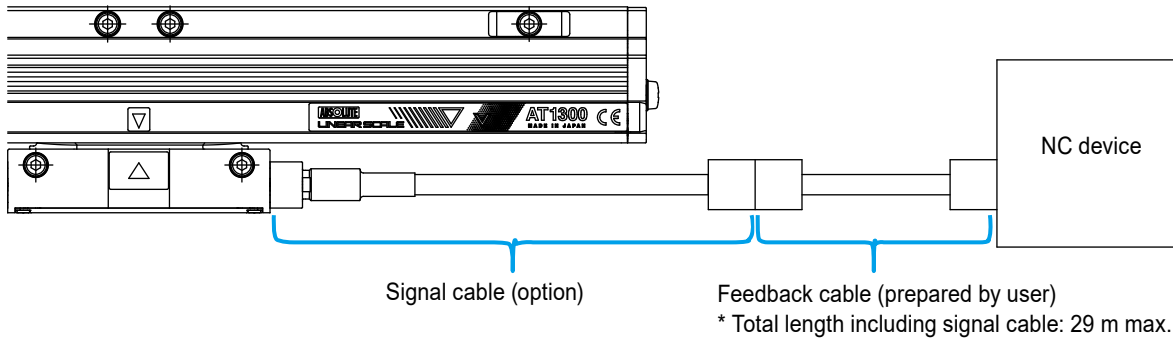

Tips

- The signal cable is an option. Select an appropriate one according to your requirements.
- For the specifications of the signal cable output signals, etc., refer to "4 Specifications" (page 33)
- When connecting our signal cable to the your ordered cable, the total length of the cables should be 29 m maximum.

2.3.2 Bend Radius of the Signal Cable

The bend radius of the cable shall be kept within the following range.

The bend radius indicated below also applies to the case when the signal cable is extended.

■ When the Detector moves (cable is repeatedly bent)

-> Bend radius of the cable: 100 mm or more

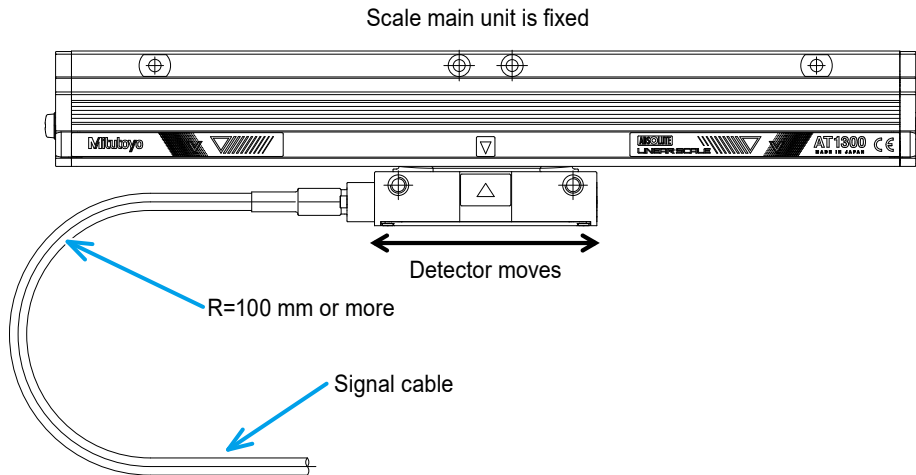

■ When the Detector is fixed (cable is fixed)

-> Bend radius of the cable: 50 mm or more

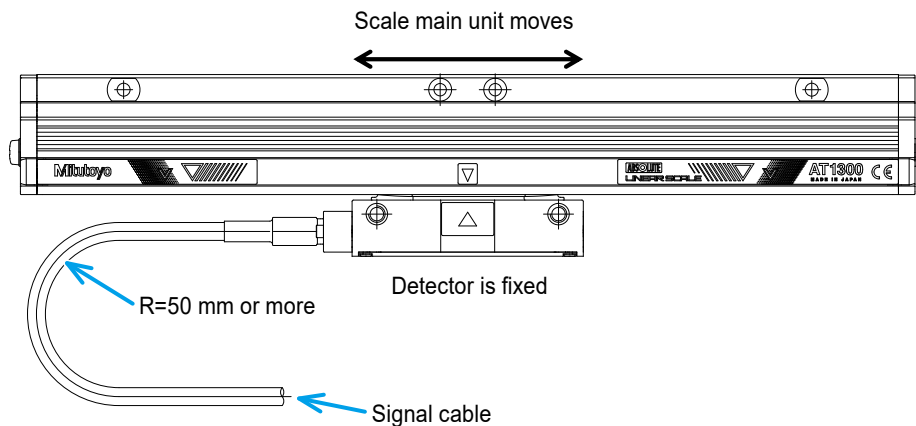

NOTICE

If a cable bend radius exceeds the allowable range, it could result in breakage of the wires or other problems. Also, note with caution that the scale is no longer guaranteed in such a case.

Tips

- The signal cable is an option. Also, the cable clamps or other fasteners are not supplied as accessories, therefore, they must be prepared by the user.
- For the details of how to fix the cable, refer to "3.4.3 Precautions on Fixing the Cables" (page 30)

2.4 Precautions on Designing Scale Unit Mounting Surface

The following describes some design points regarding the “mounting surface” for installing the scale unit onto the machine main unit.

In addition, refer to "4.7 External View and Dimensional Drawings of the Scale Main Unit".

2.4.1 Datum Point Position for the Length Variation and ABS Origin

The fixing parts of the scale unit are divided into the full-fixing part (one in longitudinal direction) and the elastic-fixing parts. The position of this full-fixing part becomes "datum point position for length variation of the scale main unit", which is the reference point for the scale's mechanical expansions and contractions due to changes in temperature change. Note with caution that users are not able to change this datum point position.

The internal electrical "ABS origin" is set at the center of the effective length for all models.

Scale main unit specifications			External view
Specifications	Datum point position for length variation	ABS origin	
High precision	Effective length center	Effective length center	
High rigidity	Effective length center	Effective length center	

2.4.2 Counting Direction

The absolute value data becomes zero at the origin mark position of the scale main unit (ABS origin: the center of the effective measurement length). Also, when the Detector is moved rightward in the diagram below, the output serial data will increase the count (i.e., to the + side).

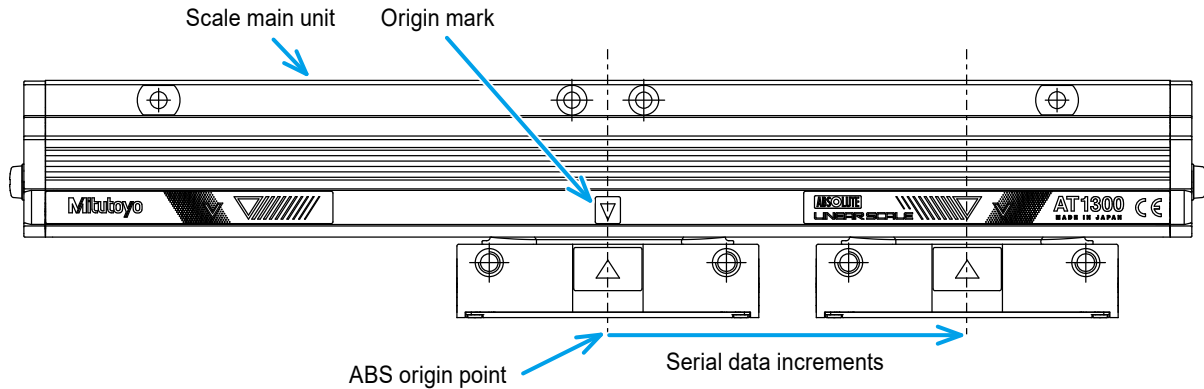

2.4.3 Checking the Maximum Travel Distance and Effective Length

Make sure that the scale's maximum travel distance (L_1) is greater than the maximum travel distance of the machine.

For the details of the effective length (L_0) and the maximum moving amount (L_1), refer to [4.7 External View and Dimensional Drawings of the Scale Main Unit](#) (page 58)

Also, note that the specified accuracy guaranteed range is limited to within the effective length.

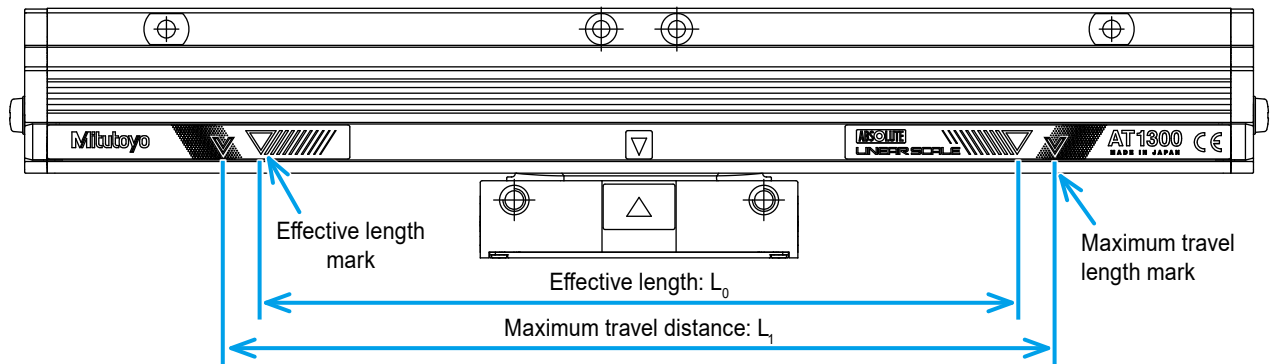

Tips

- When checking the travel range of the scale installed on the machine, make sure the maximum travel range of the machine main unit does not exceed the L_1 shown above and that the required accuracy range is within the L_0 shown above.
- If the maximum travel distance or the effective length of the scale is insufficient, a larger-size scale may have to be used.

2.4.4 Scale Main Unit Mounting Directions and Cover Preparations

When installing this product, be sure to install the cover also so that cutting oil, chips, etc. do not splatter onto the scale main unit.

Only the dust proof-rubber lips are used to protect the scale opening side from the intrusion of foreign objects.

Therefore, when deciding the mounting direction of the scale main unit, give consideration to the splattering directions of the cutting oil, chips, etc., since the opening side poses a greater hazard of foreign matter intrusion than the other sides.

- The direction from which the cutting oil, chips, etc. comparatively tend to intrude

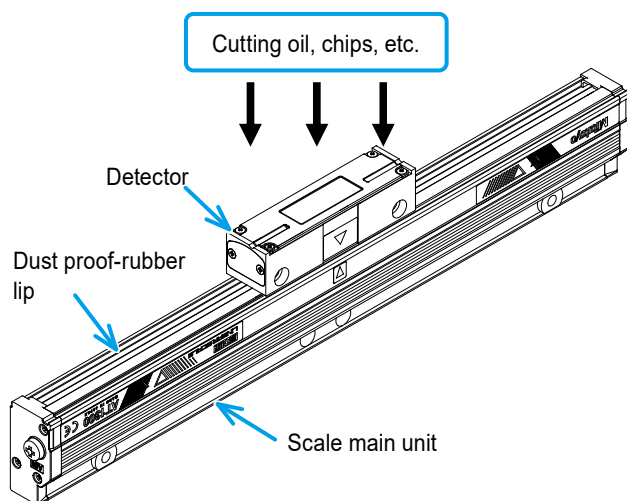

- The direction from which the cutting oil, chips, etc. comparatively tend not to intrude

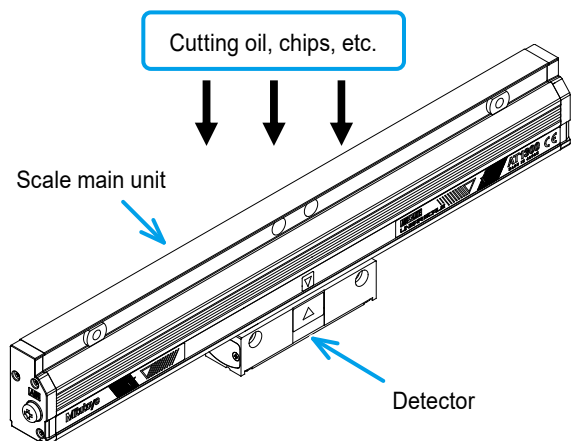

■ Mounting direction of scale main unit

● Longitudinal direction

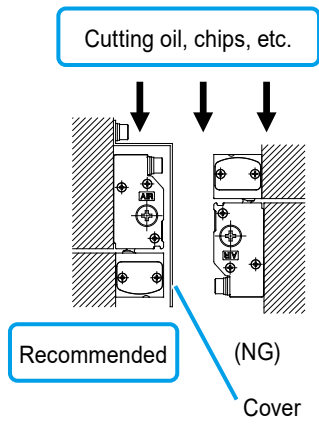

● Horizontal direction

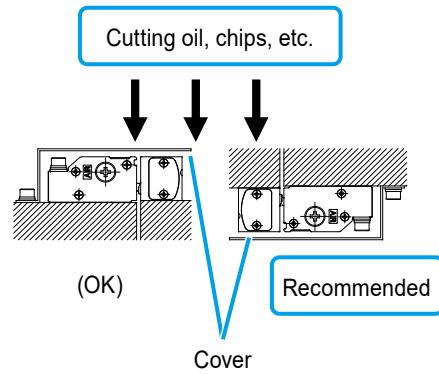

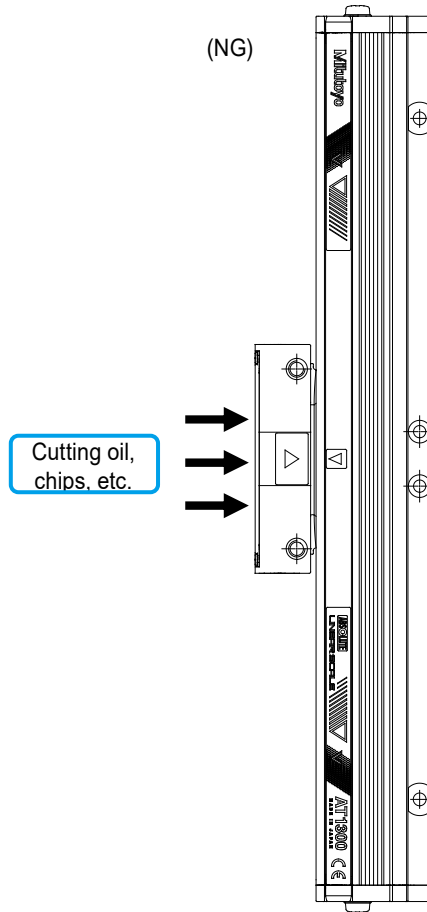
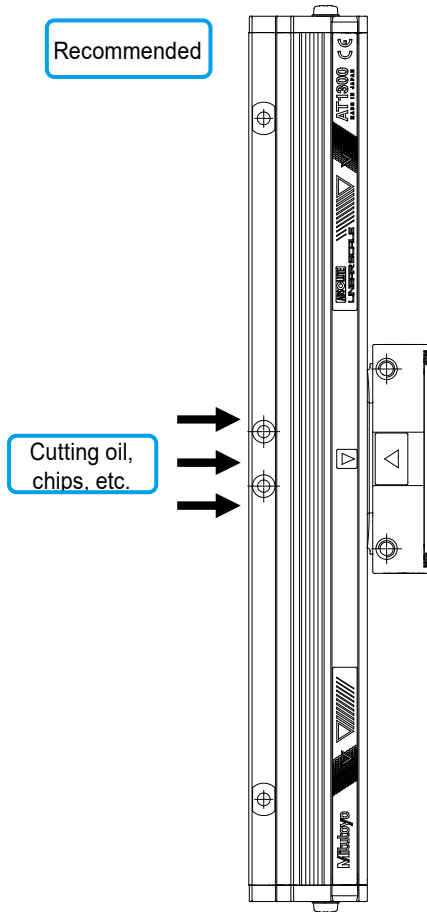

● Vertical direction



2.4.5 Precautions on Designing the Mounting Surface

The following describes precautions on designing the mounting surface.

For details of the mounting specifications, refer to  "4.7 External View and Dimensional Drawings of the Scale Main Unit" (page 58)

For details of the mounting procedures, refer to  "3 Installation onto the Machine Main Unit" (page 17)

■ Precautions

- The mounting surfaces of the scale main unit and the Detector must be machine-processed to be that.

Tips

Position dimensions and surface precision required for the machined surface differ depending on the scale main unit specification (H: high precision specification. S: high rigidity specification).

- There is a gap between the scale main unit and the Detector mounting surfaces. Therefore, remove it by the machine processing so that the gap is within the following processing tolerance. When adjusting the position by inserting a spacer, etc., be sure to measure the gap before mounting the scale.
 - ABS AT1300-H (high precision specification): 1.6 ± 0.1 mm
 - ABS AT1300-S (high rigidity specification): 1 ± 0.1 mm
- When mounting the scale main unit, the position must be adjusted in the longitudinal direction, as indicated in the figure in the next page.
It is recommended to use positioning pins, etc. to simplify the position adjustment.
Note that the longitudinal reference for positioning the scale main unit is the aluminum frame surface.
- The horizontal mounting reference of the scale main unit are as follows.
 - ABS AT1300-H (high precision specification): mounting block surface
 - ABS AT1300-S (high rigidity specification): aluminum frame surface
- Use the head fixing blocks to adjust the clearance between the scale main unit and the Detector.
- Here, the diagram of ABS AT1300-S is used for the explanation. Follow it for ABS AT1300-H as well.

2 Setup for Installation

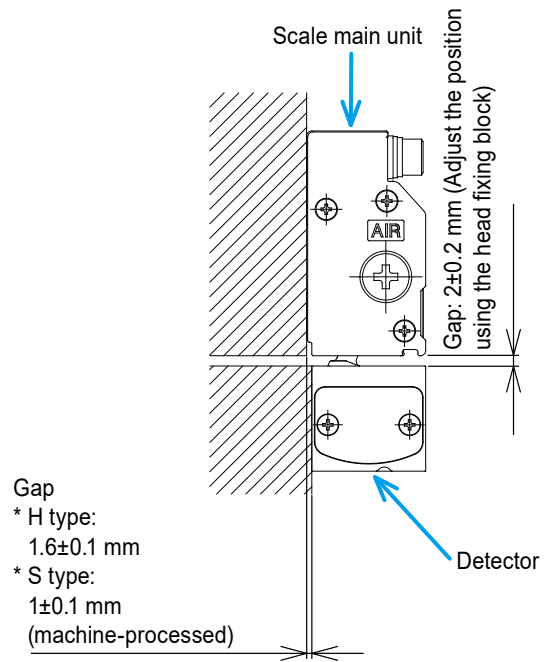
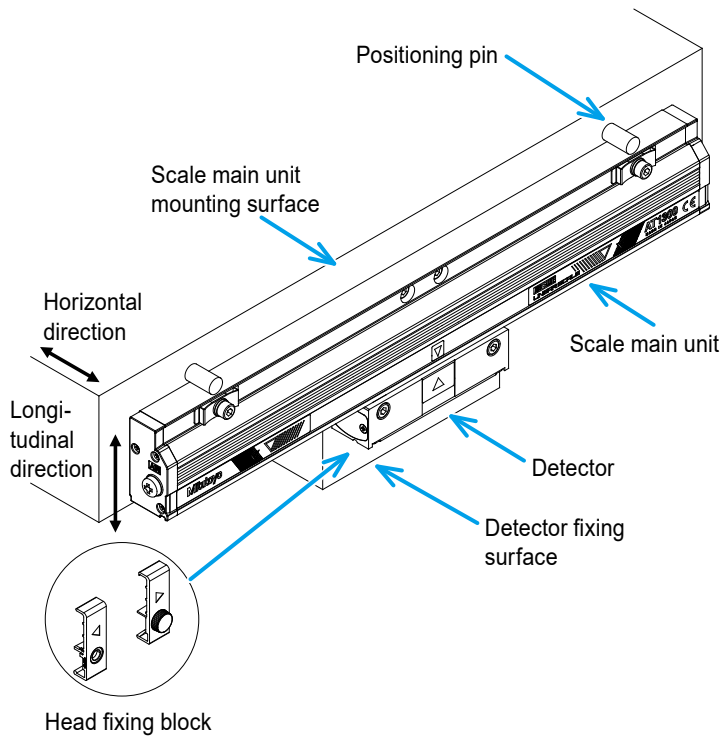

3 Installation onto the Machine Main Unit

This chapter describes the procedures, methods, and precautions required when mounting this product onto the machine main unit.

3.1 Procedure for Installation onto the Machine Main Unit

The following describes the summary of the procedure for installing this product onto the machine main unit.

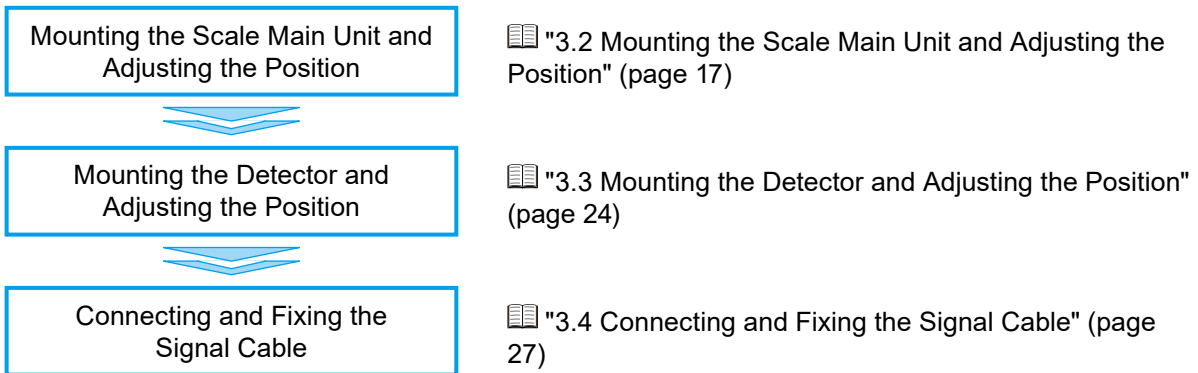

Details of each step are described in the following pages.

Tips

The installation procedure and method for ABS AT1300-H (high precision specification) and ABS AT1300-S (high rigidity specification) are different. See the explanation for the corresponding model.

3.2 Mounting the Scale Main Unit and Adjusting the Position

3.2.1 Checking the Mounting Surface, etc.

Refer to "2.4.5 Precautions on Designing the Mounting Surface" and "4.7 External View and Dimensional Drawings of the Scale Main Unit", and make sure that the positional accuracy between the scale main unit and the Detector mounting surfaces and the surface accuracy are within the specified ranges.

3.2.2 Mounting the Scale Main Unit

■ ABS AT1300-H (high precision specification)

- 1 Temporarily fix it to the scale main unit fixing surface of the machine main unit with the supplied screws (to the extent that it does not move even if you release your hands from the scale main unit).

NOTICE

When temporarily fixing the scale unit, do not fix the Detector.

Target	Screw to use	Effective length	Quantity
Mounting block (both end parts of scale main unit)	a: Hex socket head cap screw M6 x 25 + spring washer (M6) combined	100 mm–1000 mm	Two each
Full-fixing part (Datum point position for length variation due to temperature changes)	b: Hex socket head cap screw M4 x 16 + spring washer (M4) combined	100 mm–1000 mm	One each
Elastic-fixing parts	c: Hex socket head cap screw M4 x 10 + spring washer (M4) combined	100 mm–500 mm	—
		600 mm–1000 mm	Two each

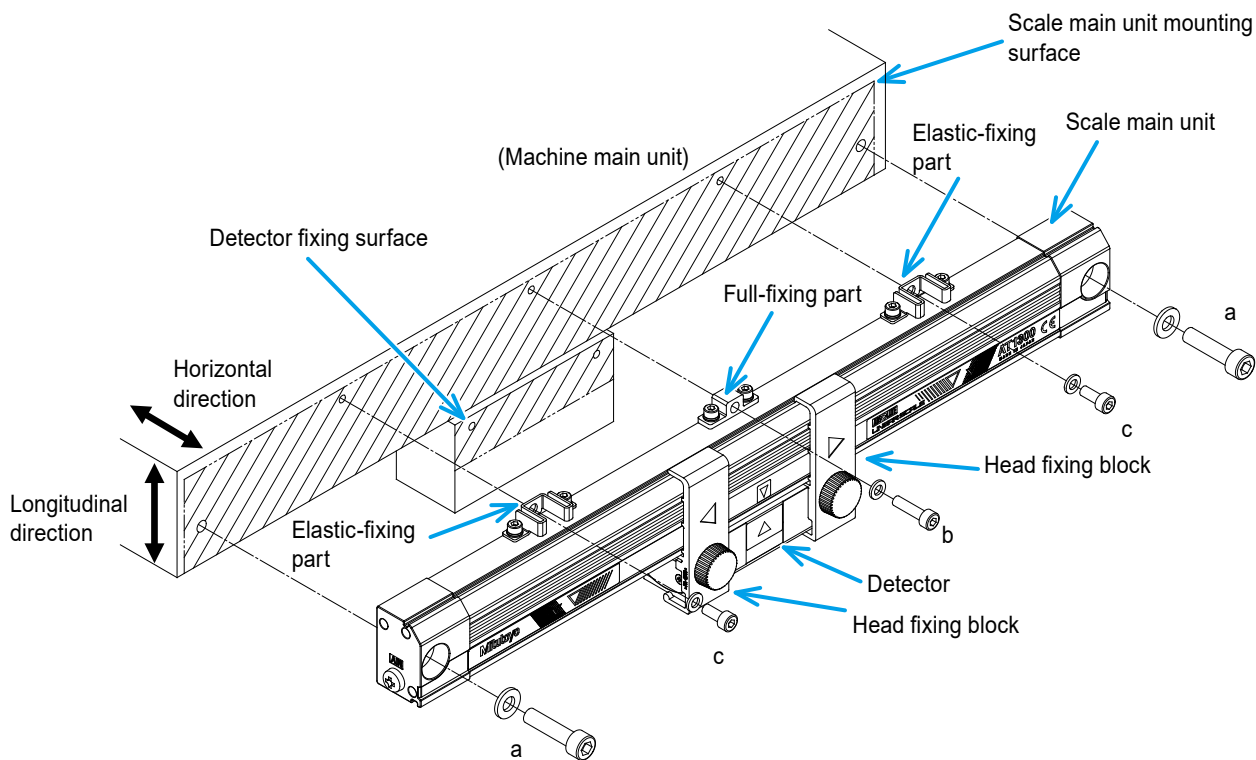

3 Installation onto the Machine Main Unit

NOTICE

The head fixing blocks that fix the Detector define the positional relationship between the scale main unit and the Detector.

When mounting the scale unit on the machine main unit, do not remove the head fixing blocks in order to keep the positional relationship.

2 Adjust the longitudinal direction of the scale.

NOTICE

The position of the scale unit of this product does not need to be adjusted in the horizontal direction (it depends on the accuracy of the machine main unit mounting surface). However, the position and dimension in the longitudinal direction must be adjusted and checked.

Adjust and check the position and dimension of the scale main unit R reference surface by referring to the external view and dimensional drawings of the scale unit.

For details of the external view and dimensional drawings, refer to  "4.7 External View and Dimensional Drawings of the Scale Main Unit" (page 58)

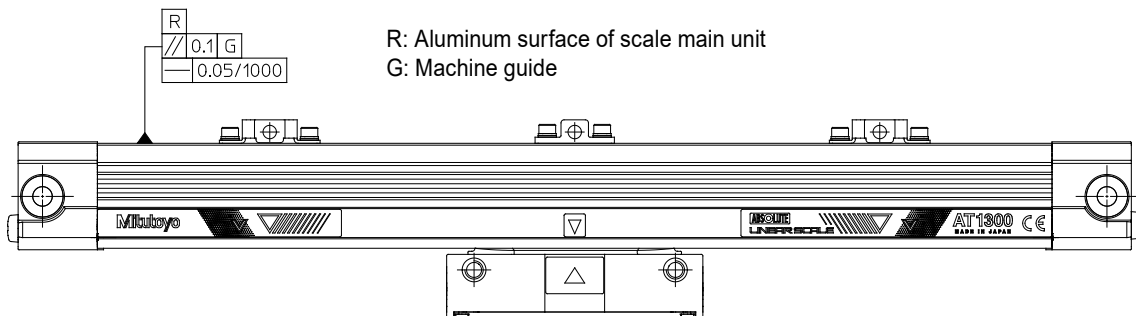

NOTICE

As described in "2.4.5 Precautions on Designing the Mounting Surface", this task can be simplified by using the positioning pins, etc. However, after mounting, the dimensions must be checked.

3 Installation onto the Machine Main Unit

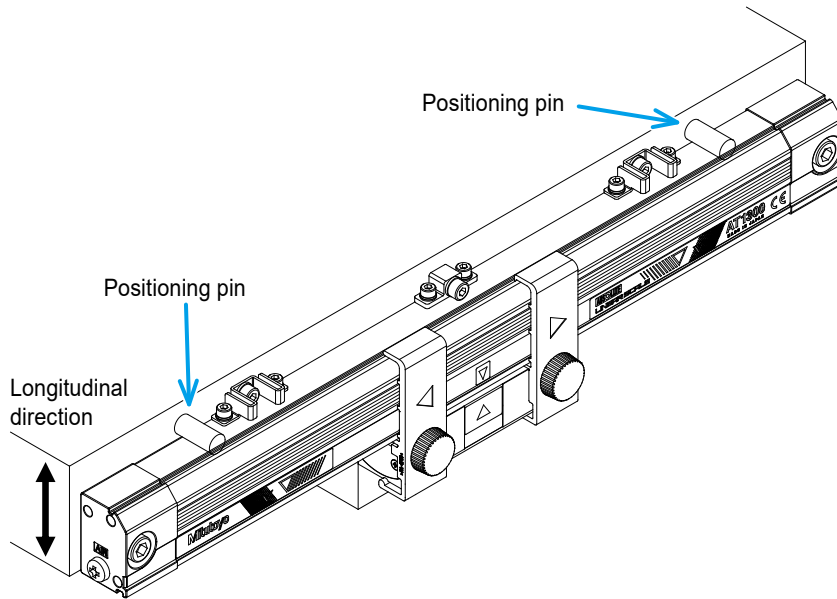

- 3** After adjusting and checking the position and dimensions in the longitudinal direction of the scale main unit, fully tighten the fixing screws.

NOTICE

Note the following:

* Tightening torque of screw

M4: 3 N·m

M6: 9 N·m

* Tightening procedure of screw

Be sure to tighten the full-fixing part (center part of scale main unit) first, and then tighten the elastic-fixing parts.

■ ABS AT1300-S (high rigidity specification)

- 1 Temporarily fix it to the scale main unit fixing surface of the machine main unit with the supplied screws (to the extent that it does not move even if you release your hands from the scale main unit).

NOTICE

When temporarily fixing the scale main unit, do not fix the Detector.

Target	Screw to use	Effective length	Quantity
Full-fixing parts (two locations at the center of the scale main unit)	a: Hex socket head cap screw M4 x 16 + spring washer (M4) combined	100 mm–2200 mm	Two each
		100 mm–450 mm	Two each
Elastic-fixing parts	b: Hex socket head cap screw M4 x 25 + spring washer (M4) + Dedicated leaf spring combined	500 mm–800 mm	Four each
		900 mm–1200 mm	Six each
		1300 mm–1600 mm	Eight each
		1800 mm–2000 mm	10 each
		2200 mm	12

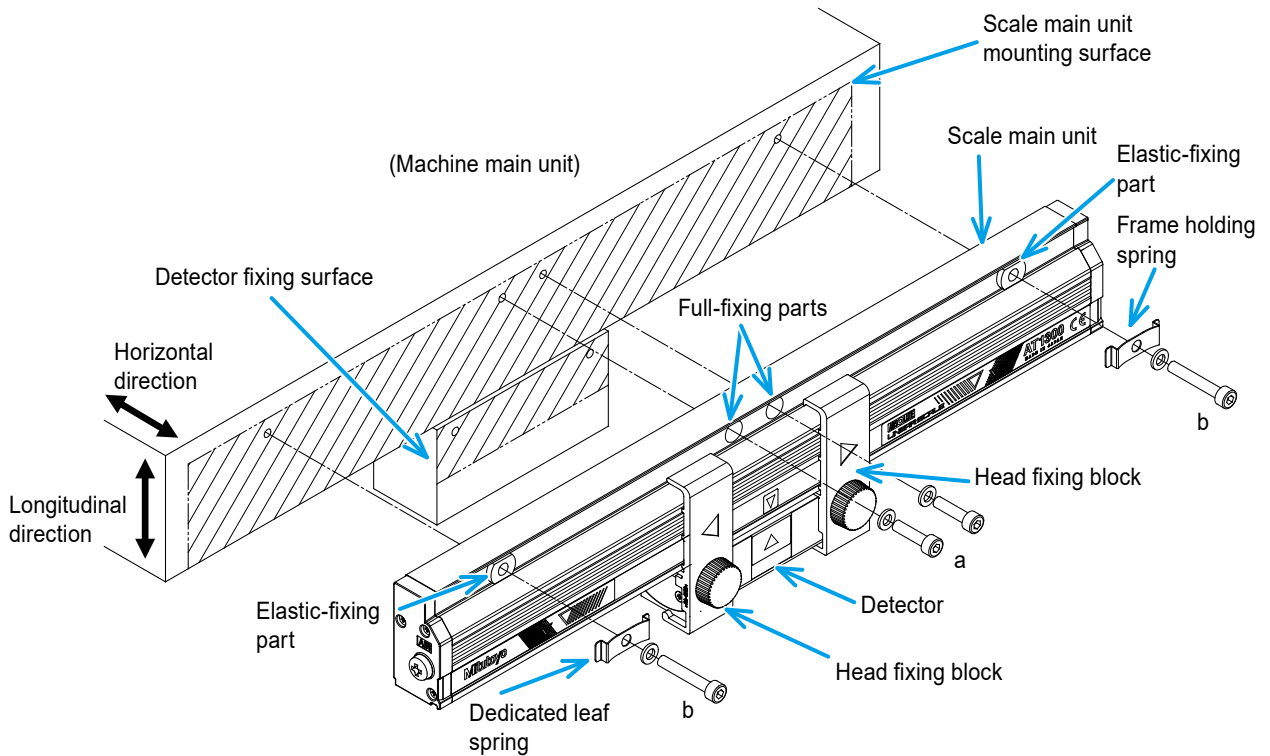

NOTICE

The head fixing blocks that fix the Detector define the positional relationship between the scale main unit and the Detector.

When mounting the scale unit on the machine main unit, do not remove the head fixing blocks in order to keep the positional relationship.

3 Installation onto the Machine Main Unit

2 Adjust the longitudinal direction of the scale.

NOTICE

The position of the scale unit of this product does not need to be adjusted in the horizontal direction (it depends on the accuracy of the machine main unit mounting surface). However, the position and dimension in the longitudinal direction must be adjusted and checked.

Adjust and check the position and dimension of the scale main unit R reference by referring to the external view and dimensional drawings of the scale unit.

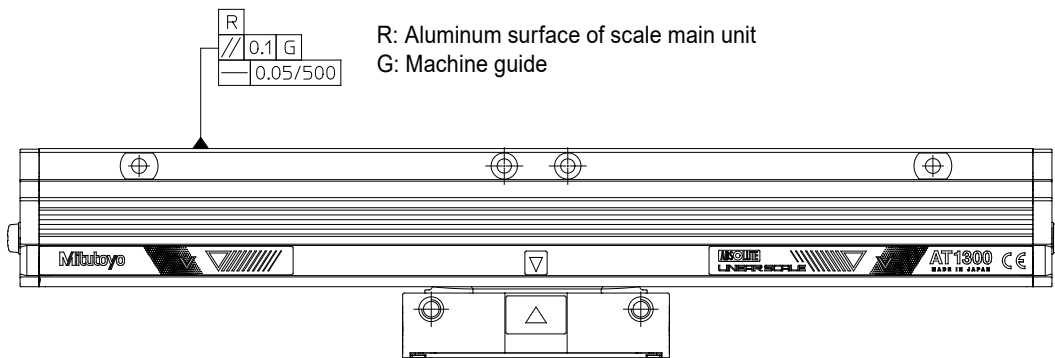

NOTICE

As described in "2.4.5 Precautions on Designing the Mounting Surface", this task can be simplified by using the positioning pins, etc. However, after mounting, the dimensions must be checked.

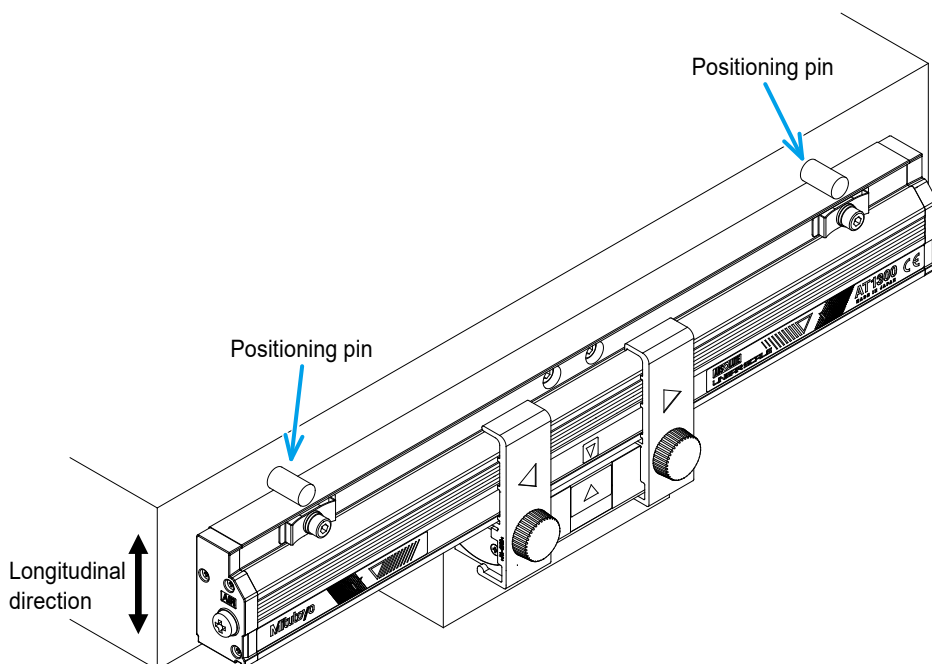

3 Installation onto the Machine Main Unit

- 3 After adjusting and checking the position and dimensions in the longitudinal direction of the scale main unit, fully tighten the fixing screws.

NOTICE

Note the following:

* Tightening torque of screw

M4: 3 N·m

* Tightening procedure of screw

Be sure to tighten the full-fixing parts (two locations at center part of scale main unit) first, and then tighten the elastic-fixing parts.

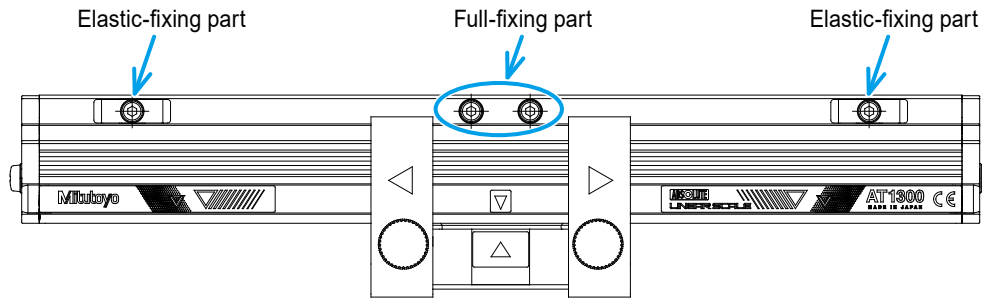

* Fixed state of elastic-fixing parts

The fixing state of the elastic-fixing part is shown below.

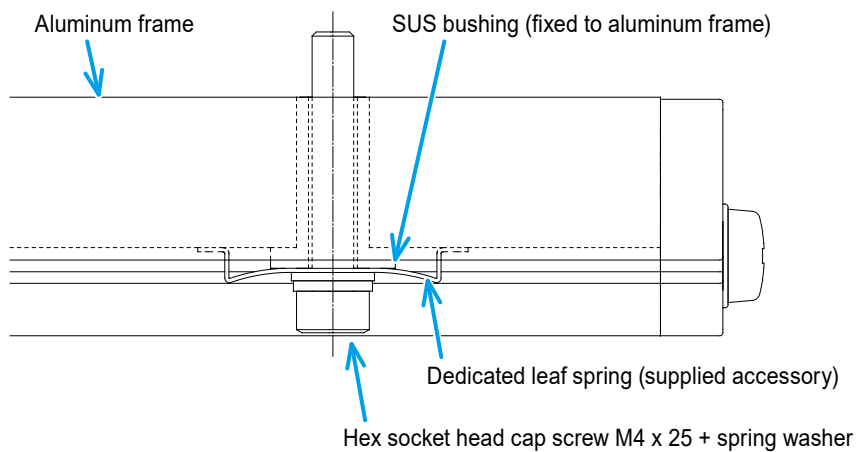

3.3 Mounting the Detector and Adjusting the Position

After completing the steps described in "3.2 Mounting the Scale Main Unit and Adjusting the Position", follow the procedures below to attach the Detector.

The procedure for mounting the Detector is the same for H specification (high precision specification) and S specification (high rigidity specification).

3.3.1 Installing the Detector

- 1 Check the parallelism of the Detector mounting surface.

For details, refer to  "4.7 External View and Dimensional Drawings of the Scale Main Unit" (page 58)

- 2 Remove the decorative screws (two locations) of the head fixing blocks.

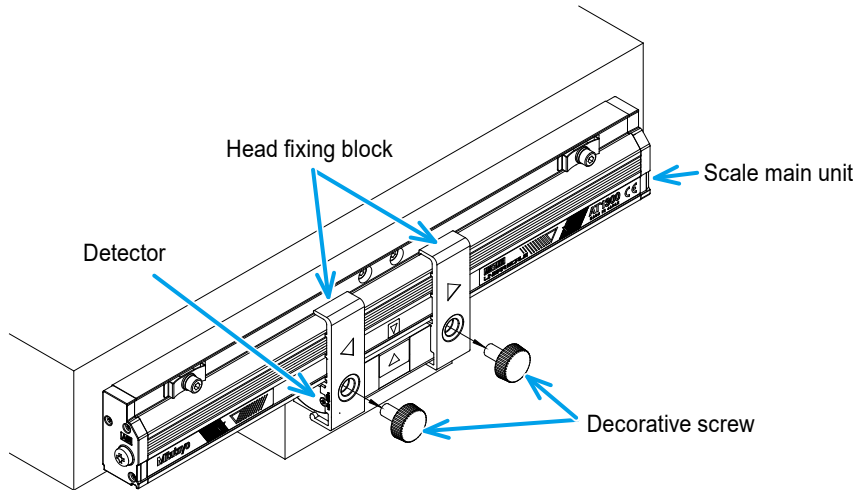

- 3 Temporarily fix the Detector with the supplied screws (to the extent that it does not move even if you release your hands from the Detector).

Screw to use	Quantity
Hex socket head cap screw M4 x 25	two

3 Installation onto the Machine Main Unit

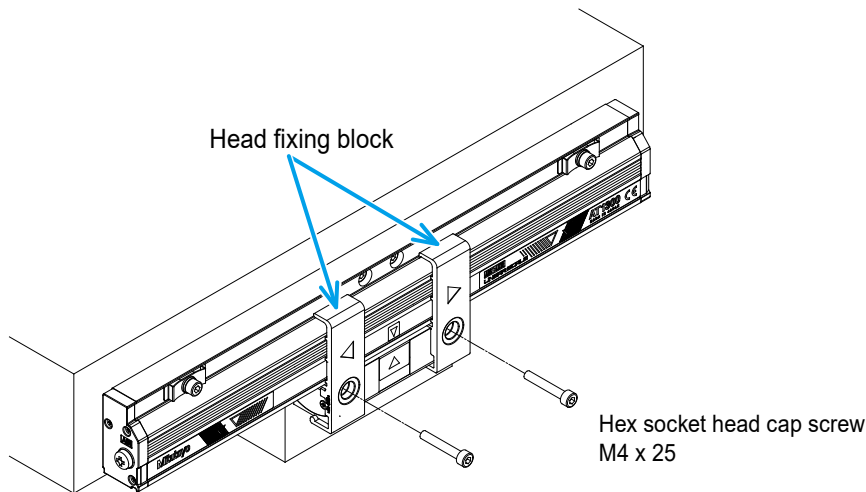

NOTICE

Do not remove the head fixing blocks during the operation.

4 Adjust the position of the Detector and then fully fix it.

The position of the Detector does not need to be adjusted in the horizontal direction (it depends on the accuracy of the machine main unit mounting surface). However, the position and dimension in the longitudinal direction (gap between the aluminum frame of the scale main unit and the Detector) must be adjusted and checked.

- 1 Slide the head fixing blocks left and right.
 - 2 Adjust the Detector to the following position with respect to the head fixing blocks on both sides.
 - » Position where the head fixing blocks smoothly enter between the Detector and the scale main unit.
 - 3 Fully fix the Detector.
 - » After adjusting and checking the position and dimensions in the longitudinal direction of the Detector, fully tighten the fixing screws.
- Screw tightening torque (M4): 3 N·m

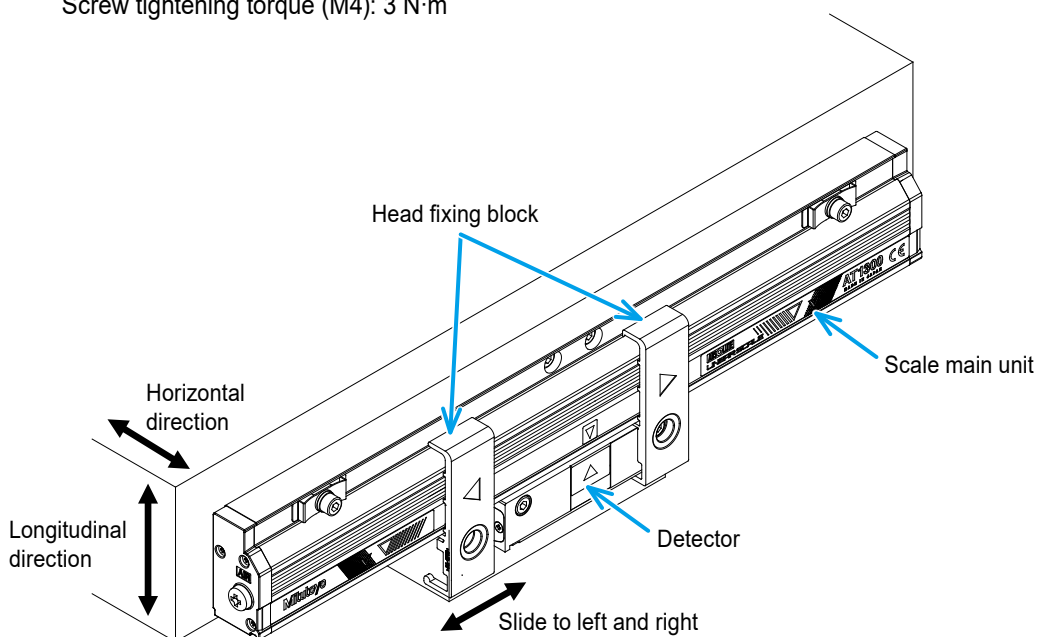

3 Installation onto the Machine Main Unit

- 5** Remove the head fixing blocks from scale main unit.

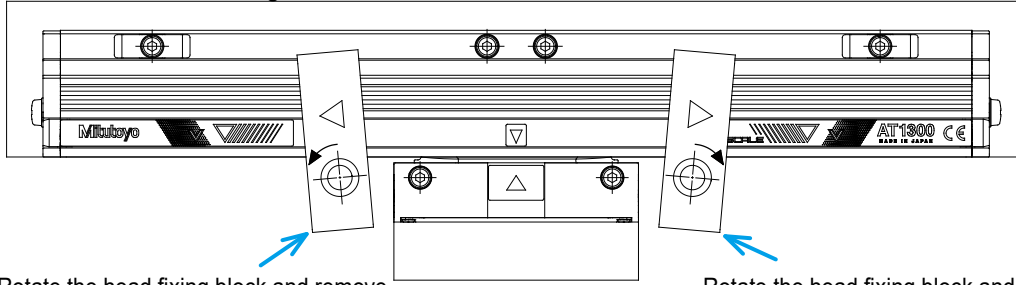

Rotate the head fixing block and remove

Rotate the head fixing block and remove

3.4 Connecting and Fixing the Signal Cable

3.4.1 Cable Connection and Operation Check

An example of the system configuration is shown below.

For the details of the cables, refer to  "4 Specifications" (page 33)

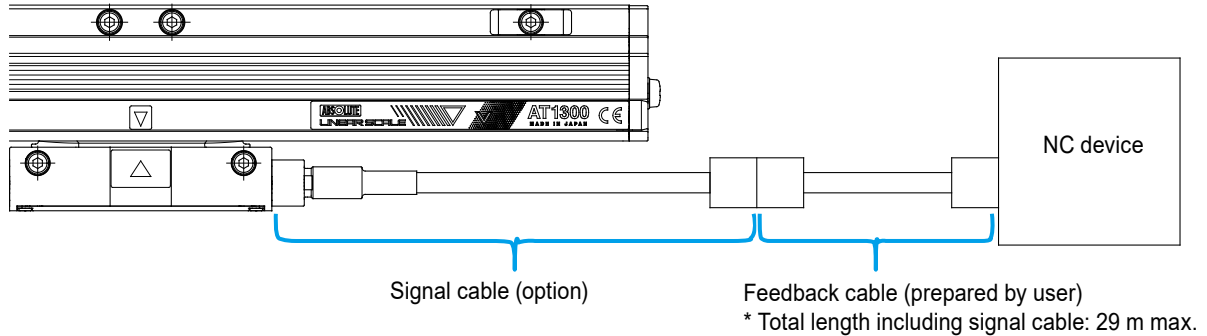

■ Connect the cables and check operations

- 1 According to "3.4.2 Connecting the Signal Cable", connect the Detector and the signal cable.
- 2 Connect the signal cable to the NC device.
- 3 Make sure the screws on the connector plug are fully tightened.

Tips

When connecting our signal cable to the your ordered cable, the total length of the cables should be 29 m maximum.

- 4 After connection of cables etc. is completed, turn on the power and check the operations, functions, and performance of the scale.

NOTICE

- After turning on the power, if the scale unit does not operate normally, check the connections first. If the scale does not operate normally even after the status of connections is checked and the power is supplied again, investigate the cause, following the instructions in "5 Troubleshooting".
- When checking the scale operations, be very careful that no cables are being pinched by the machinery.
- When connecting the connectors, if chips or other foreign objects are sandwiched in, that may cause malfunctions.

3.4.2 Connecting the Signal Cable

- 1 Decide the mounting direction of the signal cable.

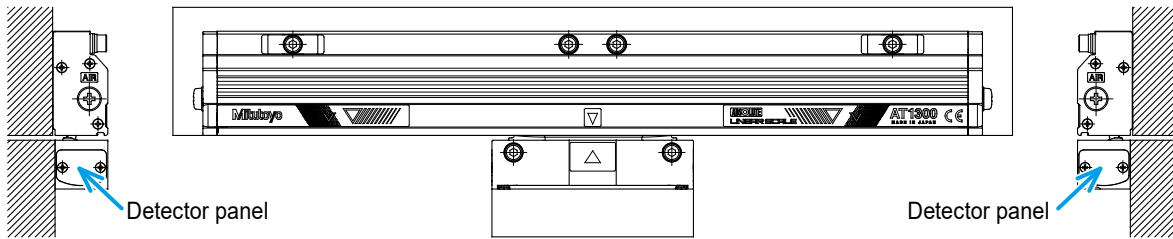

- 2 Remove the cable outlet panel at the mounting side of the signal cable.

- 3 Check that the detector head packing is attached to the Detector side.

NOTICE

The detector head packing is fitted between the Detector panel and the Detector.

When removing the Detector panel, make sure that the detector head packing does not come off. If it comes off, insert it into the groove of the Detector.

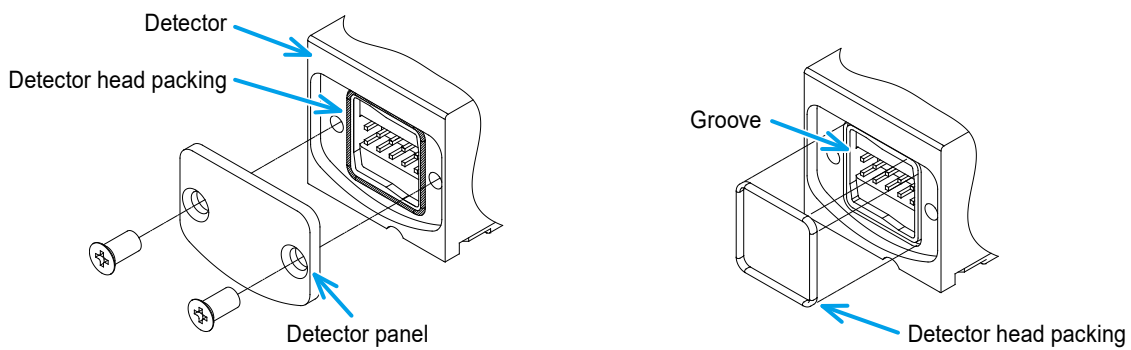

3 Installation onto the Machine Main Unit

4 Connect the Detector and the signal cable.

NOTICE

Connect it engaging the convex part of the cable outlet with the concave part of the connector.

A detector head packing is set between the Detector and the connector to ensure water-resistance performance. When connecting the cable, make sure to confirm that the detector head packing is set in the groove of the signal cable outlet.

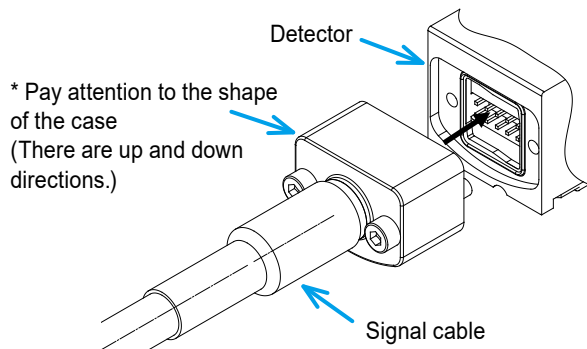

Tightening torque of connector fixing screw

Hex socket head cap screw (M2.6): 0.8 N·m

3.4.3 Precautions on Fixing the Cables

Be sure to note the following content when fixing the cables.

- 1 Perform wiring paying attention to the twisting or bends of the cables.

NOTICE

Note that the signal cable and feed back cable may malfunction if bundled with other cables that may cause electrical noise, or if they are located near a switching relay dealing with a large current.

- 2 Use cable clamps or other fasteners to secure the cables.

NOTICE

Note the following:

- Do not bend the cables.
Also, do not bend the cables beyond the bend radius range specified in "2.3.2 Bend Radius of the Signal Cable".

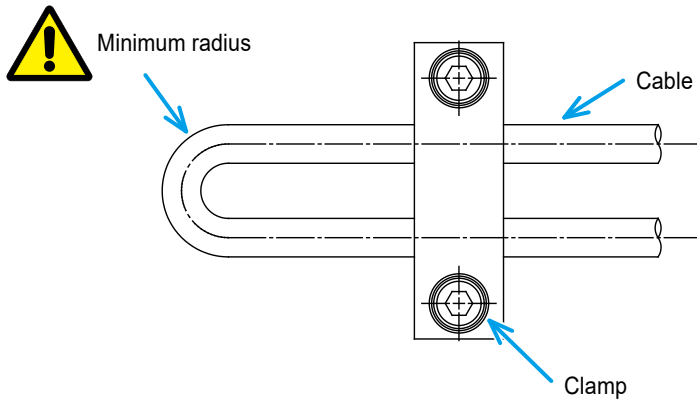

- If the cables are going to be repeatedly bent, try to reduce stress applied to near the root of the clamping part.

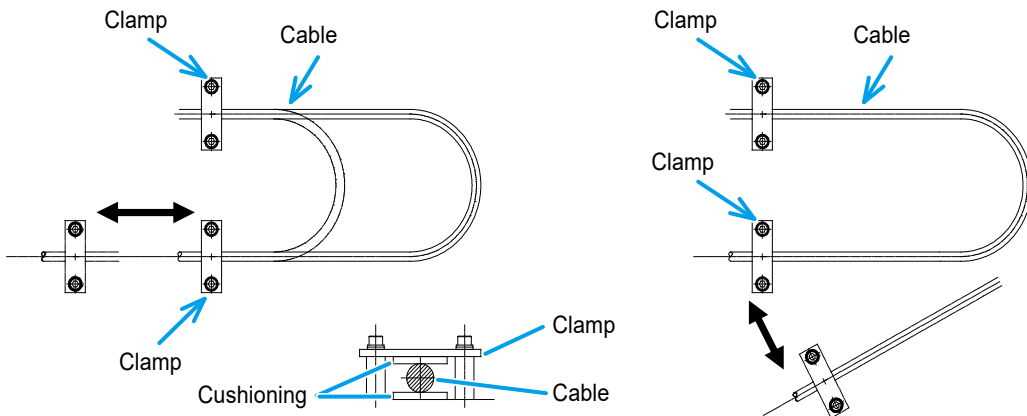

3 Installation onto the Machine Main Unit

NOTICE

- Consider the shake due to vibration, etc. given to connectors.

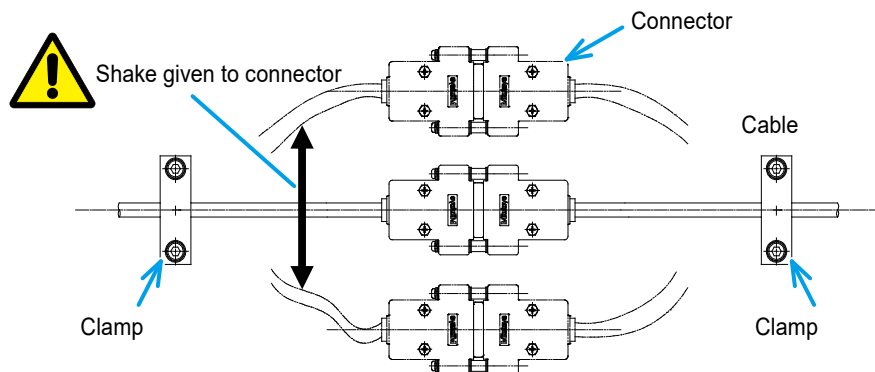

- Make sure that excessive bends do not occur on the root of on the signal cable in the full stroke.

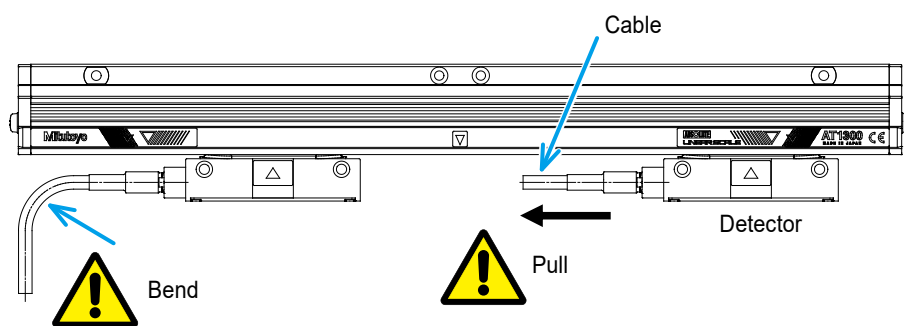

MEMO

4 Specifications

This chapter describes the specifications of this product.

4.1 Specifications

Items	High precision specification	High rigidity specification
	ABS AT1300-H Series	ABS AT1300-S Series
Scale main unit installation specifications	Elastic fixing at three or five points	Elastic fixing at multiple points
Datum point position for length variation due to temperature changes	Center of effective measurement length	
ABS origin point (output data is 0)	Center of effective measurement length	
Effective measurement length (mm)	100, 150, 200, 250, 300 350, 400, 450, 500, 600 700, 750, 800, 900, 1000	100, 200, 300, 400, 500, 600 700, 800, 900, 1000, 1100 1200, 1300, 1400, 1500 1600, 1800, 2000, 2200
Detection method	Photoelectric type ABS linear encoder	
I/O method	High-speed serial interface	
Resolution (μm)	0.001/0.01/0.05	
Maximum response speed (m/min)	180	
Indication precision (μm) at 20 °C	2+2Lo/1000 Lo: Effective measurement length (mm)	3+3Lo/1000 Lo: Effective measurement length (mm)
Coefficient of thermal expansion	$\approx 8 \times 10^{-6}/\text{K}$	
Vibration resistance (55 Hz–2000 Hz)	$\leq 147 \text{ m/s}^2$	$\leq 196 \text{ m/s}^2$
Shock resistance (1/2 sin, 11 ms)	$\leq 196 \text{ m/s}^2$	$\leq 343 \text{ m/s}^2$
Power supply voltage/current consumption	5 VDC \pm 10 % / 270 mA (maximum value)	
Signal cable length	Maximum 29 m (signal cable + feedback cable)	
Used/storage temperature and humidity range	0 °C–50 °C / -20 °C–70 °C, 20 %–80 % RH (non condensation)	
Interface	Specifications made by Mitutoyo ENSIS, Mitsubishi Electric Corporation, FANUC Corporation and YASKAWA Electric Corporation	
CE marking/UKCA marking	EMC Directive/Electromagnetic Compatibility Regulations : EN 61326-1 Immunity test requirement: Clause 6.2 Table 2 Emission limit: Class B RoHS Directive/The Restriction of the Use of Certain Hazardous Substances in Electrical and Electronic Equipment Regulations: EN IEC 63000	

4.2 Signal Cable Specifications

4.2.1 Output Signal

■ Discrete-wire specification cable

Cable color	Signal	Cable color	Signal
Brown	DT	White	+5 V
Red	/DT	Black	GND
Orange	RQDT	Shielded wire	Frame ground
Yellow	/RQDT		

* Connect the shielded wire to the ground bar.

■ Specification cable with alarm indication function (D sub connector: pin contact, 15 pins)

Pin number	Signal	Pin number	Signal
1, 2, 13	GND	7	RQDT
3, 4, 11	+5 V	8	/RQDT
5	DT	15	Frame ground
6	/DT		

■ FANUC connector specifications

Pin number	Signal	Pin number	Signal
1	SD	12,14	GND
2	*SD	18,20	+5 V
5	RQ(REQ)	16	Frame ground
6	*RQ(REQ)	3,4,7 ~ 13,15,17,19	Not used

■ Mitsubishi connector specifications

Pin number	Signal	Pin number	Signal
1	5 V	7	DT
2	GND	8	\overline{DT}
3	RQDT	5,6,9,10	Not used
4	\overline{RQDT}		
		Connector shell	Frame ground

■ YASKAWA connector specification

Pin number	Signal	Pin number	Signal
1	VCC	Connector shell	Frame ground
2	GND		
5	S	3, 4	Not used
6	/S		

4.2.2 Cable Dimensions

■ ABS AT135*/134*/138*/130*(A) (discrete-wire specification)

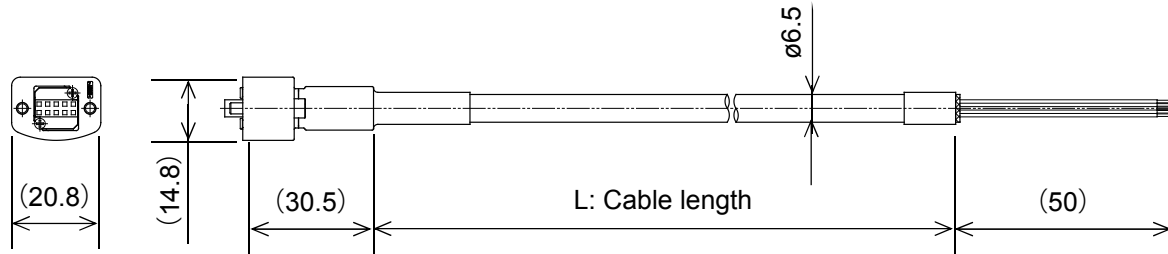

Part No.	Part name	Cable length (m)
06AFS310-1	AT1300 signal cable Ass'y (discrete-wire) 1 m	1
06AFS310-2	AT1300 signal cable Ass'y (discrete-wire) 2 m	2
06AFS310-3	AT1300 signal cable Ass'y (discrete-wire) 3 m	3
06AFS310-4	AT1300 signal cable Ass'y (discrete-wire) 4 m	4
06AFS310-5	AT1300 signal cable Ass'y (discrete-wire) 5 m	5
06AFS310-6	AT1300 signal cable Ass'y (discrete-wire) 6 m	6
06AFS310-7	AT1300 signal cable Ass'y (discrete-wire) 7 m	7
06AFS310-8	AT1300 signal cable Ass'y (discrete-wire) 8 m	8
06AFS310-9	AT1300 signal cable Ass'y (discrete-wire) 9 m	9
06AFS310-12	AT1300 signal cable Ass'y (discrete-wire) 12 m	12

4 Specifications

- ABS AT135*/134*/138*/130*(A) specification cable with alarm indication function (D sub connector: pin contact, 15 pins)

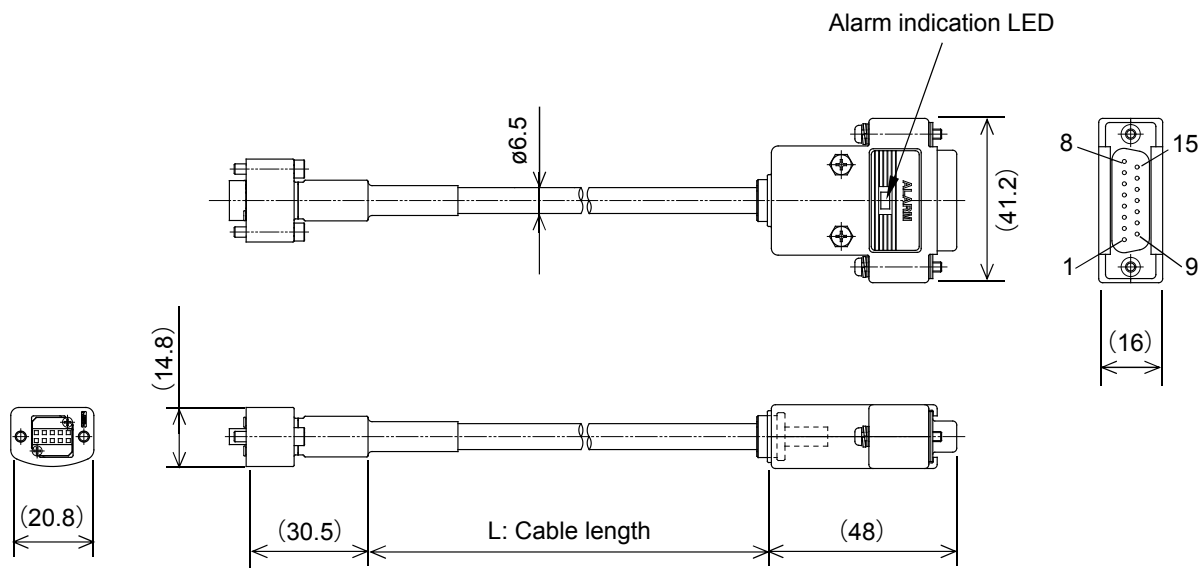

Part No.	Part name	Cable length (m)
06AFS313-1	AT1300 signal cable Ass'y (D-sub) 1 m	1
06AFS313-2	AT1300 signal cable Ass'y (D-sub) 2 m	2
06AFS313-3	AT1300 signal cable Ass'y (D-sub) 3 m	3
06AFS313-4	AT1300 signal cable Ass'y (D-sub) 4 m	4
06AFS313-5	AT1300 signal cable Ass'y (D-sub) 5 m	5
06AFS313-6	AT1300 signal cable Ass'y (D-sub) 6 m	6
06AFS313-7	AT1300 signal cable Ass'y (D-sub) 7 m	7
06AFS313-8	AT1300 signal cable Ass'y (D-sub) 8 m	8
06AFS313-9	AT1300 signal cable Ass'y (D-sub) 9 m	9
06AFS313-12	AT1300 signal cable Ass'y (D-sub) 12 m	12

■ ABS AT135* (FANUC connector specification)

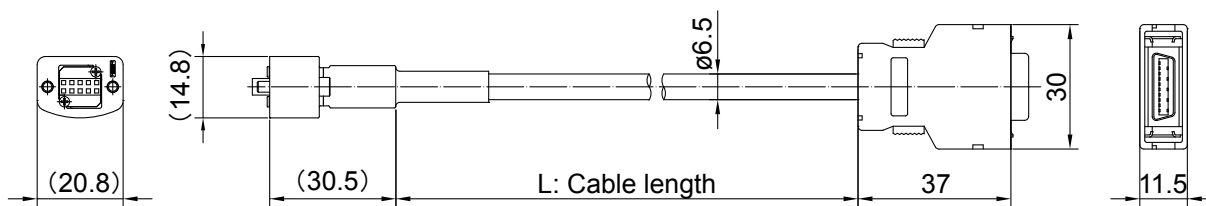

Part No.	Part name	Cable length (m)
06AFS312-1	AT1300 signal cable Ass'y (FANUC) 1 m	1
06AFS312-2	AT1300 signal cable Ass'y (FANUC) 2 m	2
06AFS312-3	AT1300 signal cable Ass'y (FANUC) 3 m	3
06AFS312-4	AT1300 signal cable Ass'y (FANUC) 4 m	4
06AFS312-5	AT1300 signal cable Ass'y (FANUC) 5 m	5
06AFS312-6	AT1300 signal cable Ass'y (FANUC) 6 m	6
06AFS312-7	AT1300 signal cable Ass'y (FANUC) 7 m	7
06AFS312-8	AT1300 signal cable Ass'y (FANUC) 8 m	8
06AFS312-9	AT1300 signal cable Ass'y (FANUC) 9 m	9
06AFS312-12	AT1300 signal cable Ass'y (FANUC) 12 m	12

■ ABS AT134*(A) (Mitsubishi connector specification)

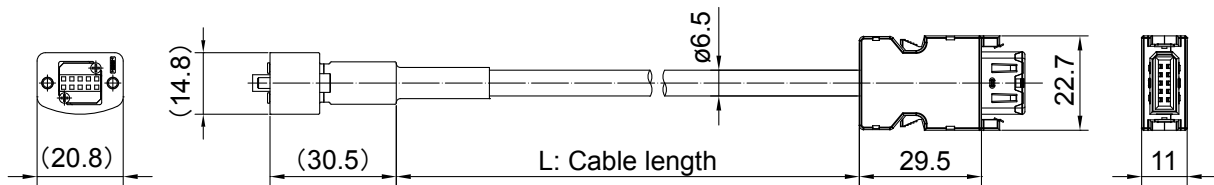

Part No.	Part name	Cable length (m)
06AFS311-1	AT1300 signal cable Ass'y (Mitsubishi) 1 m	1
06AFS311-2	AT1300 signal cable Ass'y (Mitsubishi) 2 m	2
06AFS311-3	AT1300 signal cable Ass'y (Mitsubishi) 3 m	3
06AFS311-4	AT1300 signal cable Ass'y (Mitsubishi) 4 m	4
06AFS311-5	AT1300 signal cable Ass'y (Mitsubishi) 5 m	5
06AFS311-6	AT1300 signal cable Ass'y (Mitsubishi) 6 m	6
06AFS311-7	AT1300 signal cable Ass'y (Mitsubishi) 7 m	7
06AFS311-8	AT1300 signal cable Ass'y (Mitsubishi) 8 m	8
06AFS311-9	AT1300 signal cable Ass'y (Mitsubishi) 9 m	9
06AFS311-12	AT1300 signal cable Ass'y (Mitsubishi) 12 m	12

■ ABS AT138*A (YASKAWA connector specification)

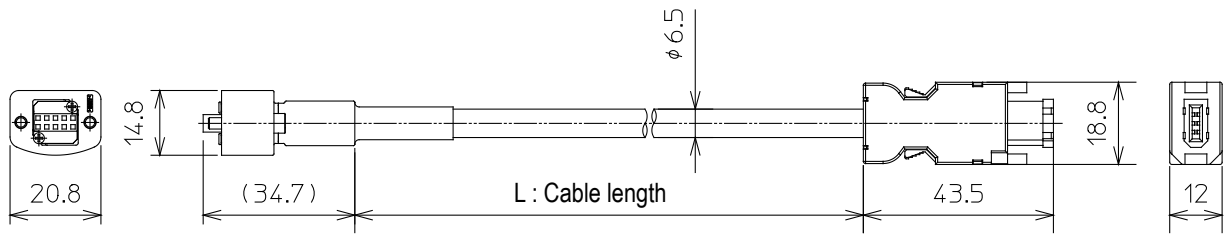

Part No.	Part name	Cable length (m)
06AGN986-1	AT1300 signal cable Ass'y(YASUKAWA) 1m	1
06AGN986-2	AT1300 signal cable Ass'y (YASUKAWA) 2 m	2
06AGN986-3	AT1300 signal cable Ass'y (YASUKAWA) 3 m	3
06AGN986-4	AT1300 signal cable Ass'y (YASUKAWA) 4 m	4
06AGN986-5	AT1300 signal cable Ass'y (YASUKAWA) 5 m	5
06AGN986-6	AT1300 signal cable Ass'y (YASUKAWA) 6 m	6
06AGN986-7	AT1300 signal cable Ass'y (YASUKAWA) 7 m	7
06AGN986-8	AT1300 signal cable Ass'y (YASUKAWA) 8 m	8
06AGN986-9	AT1300 signal cable Ass'y (YASUKAWA) 9 m	9
06AGN986-12	AT1300 signal cable Ass'y (YASUKAWA) 12 m	12

4.3 System Configuration (Example)

The following describes an example of the system configuration.
Please note that some parts need to be prepared by the user.

■ Connection example 1

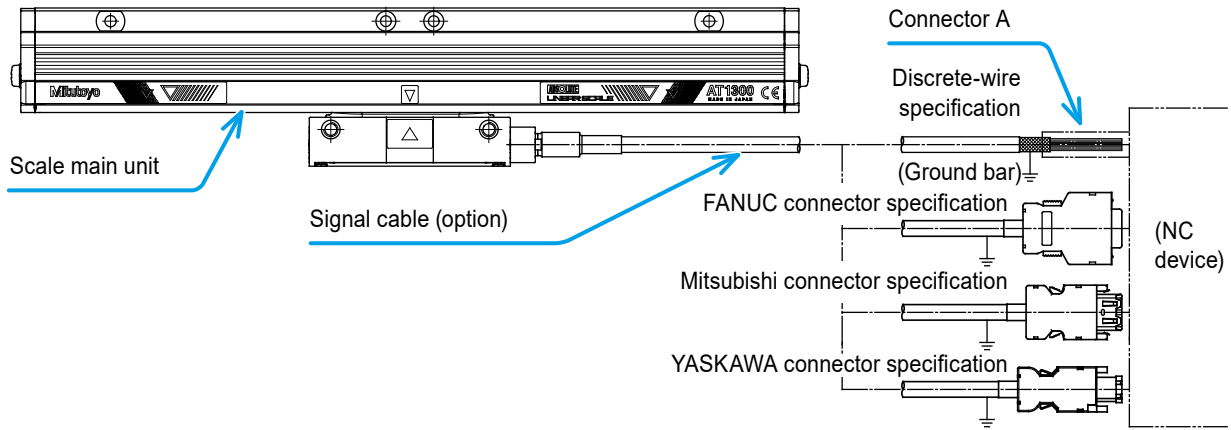

Tips

- The signal cable is an option. Prepare one according to your needs.
- The connector A shall be prepared by the user.
- Connection work for the connector A and the ground bar shall be done by the user.

■ Connection example 2

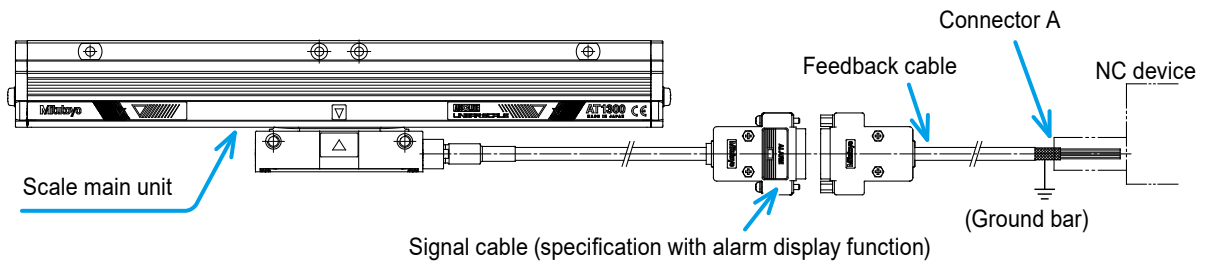

- * Connector A on the NC device is prepared by user.
- * Connection work of connector A and ground bar is performed by user.
Follow the manual of the NC device for wiring details.
- * When using the feedback cable (prepared by user), refer to the following information.
Maximum cable length (signal cable + feedback cable)... 29 m
Recommended cable material: A66L-0001-0286 (Hitachi Cable or Oki Electric Cable)

NOTICE

- When using any cable other than a recommended cable, make sure to use a shield cable and set the total amount of the impedance of the power supply line (+5 V and 0 V) to "0.65 Ω or less/total length".
- Use the feedback cable so that repeated bending does not occur.

4.4 Production of Feedback Cable (Example)

The production example of the feedback cable is shown below.

This example shows the feedback cable connected to the signal cable with alarm indication function (D sub connector 15 pins). Also follow this example for other cases.

Follow the method recommended by the NC device manufacturer to wire the connector on the NC device and cable.

4.4.1 Appearance Image of Feedback Cable and Grounding to Ground Bar

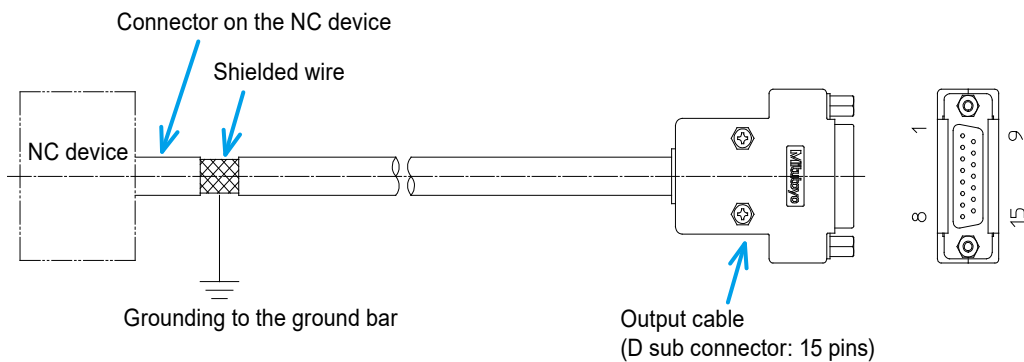

When assembling the D sub connector, make sure to conduct electricity from the cable shielded wire to the metal shell. Also, peel part of the sheath (coating) of the cable on the NC device and make sure to use the ground bar to ground the shielded wire.

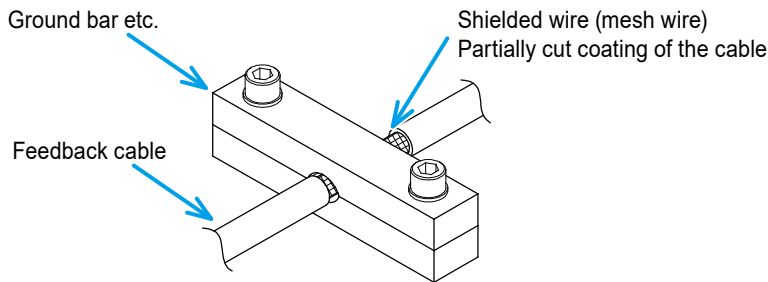

4.4.2 Assembly of D Sub Connector

- 1 Cut the sheath (coating) of the cable material into the length of the following figure.

NOTICE

Make sure not to damage the internal shielded wire.

4 Specifications

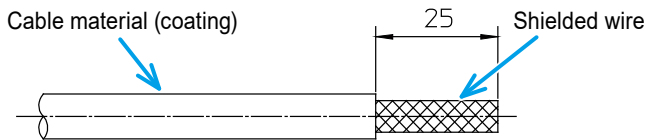

- 2** Untangle the exposed shielded wire to spread radially and cut it against the sheath.

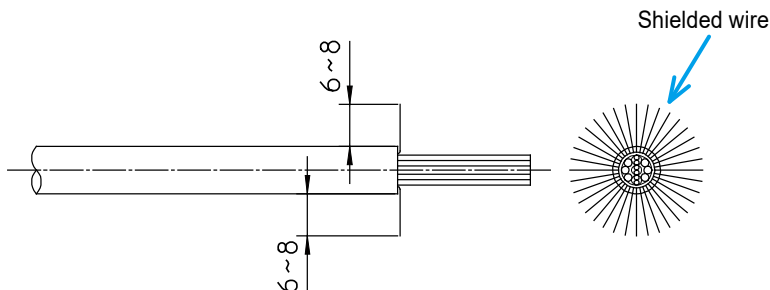

- 3** Peel the tip of the coating of the wire about 3 mm, and make a preliminary solder after twisting the conducting wires.

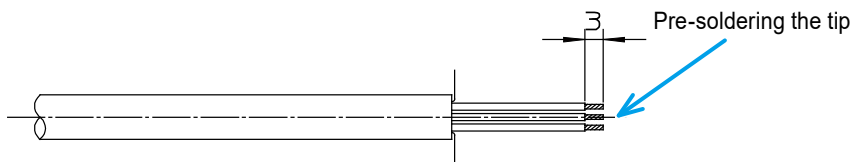

- 4** Solder each line to D sub connector (socket contact, 15 pins/supplied accessory).

NOTICE

Insert a vinyl tube (\varnothing 2 mm, L = 6 mm–8 mm) or heat shrinkable tube into each terminal part.
Bend the shielded wire to the sheath.

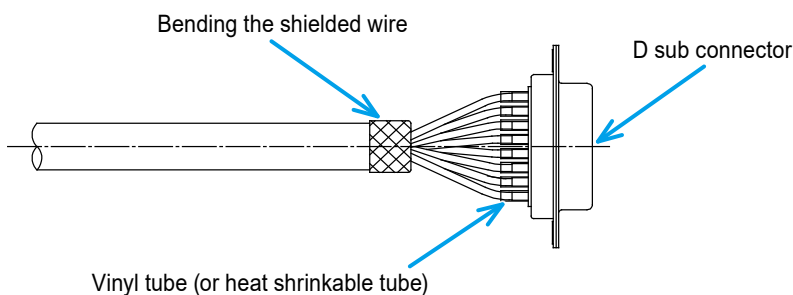

- 5** Set the connector on the plug case (supplied accessory).
- 6** Screw the shielded wire folded back at step 4 with a cable clamp material (supplied accessory).
- 7** Set the hex nuts (supplied accessory) in the plug case.
- 8** Insert the hexagonal joint stand (supplied accessory) from the connector and tighten the screws (temporary fixing).

4 Specifications

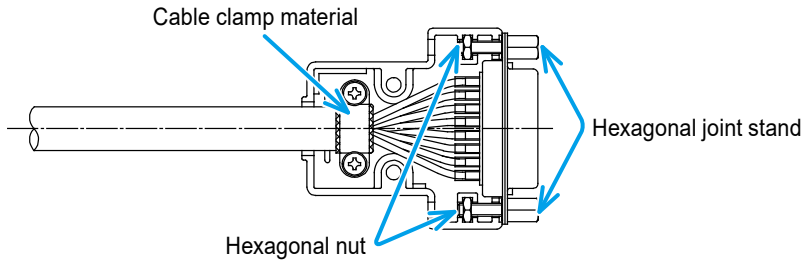

9 Place the other plug case (supplied accessory) and fix it with screws (M2.6 x 14, hex nut/supplied accessory).

10 Tighten the hexagonal joint stand temporarily fixed in step 8.

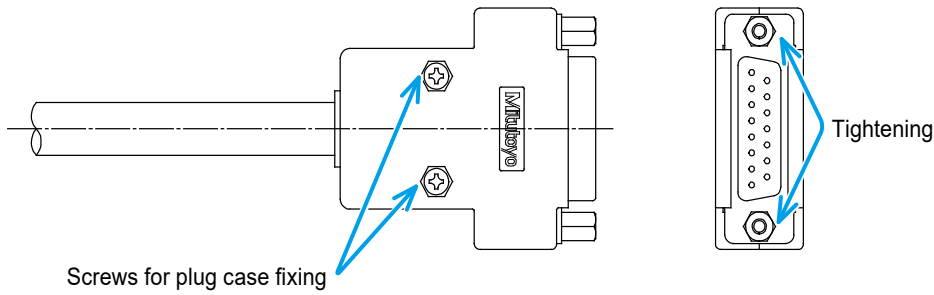

NOTICE

Apply screw locking glue for the screw units.

4.4.3 Calculation of Feedback Cable Length

When making a feedback cable, refer to the following calculation method of maximum cable length.

■ Configuration

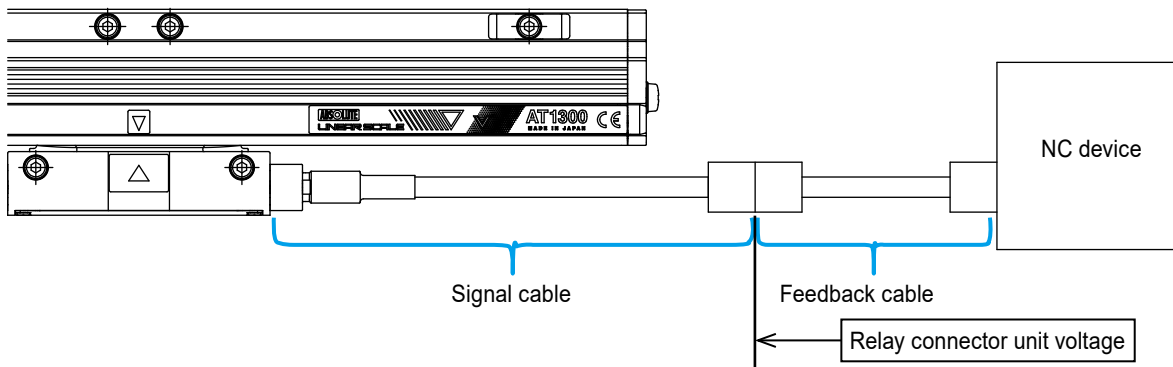

■ Condition: When the signal cable length is 1 m

Name	Specifications and symbols	Unit
Maximum cable length (Signal cable length + feedback cable length)	L	m
Wire resistance of used wire material	a	Ω/m
Number of pairs used for power supply line	b	wires
Supply voltage (minimum value) from the NC device	4.95 *1	V
Current consumption value	0.27	A
Relay connector unit voltage (minimum value)	4.5 + 0.035 *2, *3	V

*1 It is usually the standard supply voltage of the NC device.

*2 When the signal cable length is 1 m or more, a voltage drop of 0.035 V per 1 m occurs.
Consider the voltage drop in the signal cable.

*3 Confirm that the input voltage of the relay connector unit is the minimum value or more in the table above .

■ Calculation formula

Allowable voltage drop \geq (Current consumption x wire material resistance x 2 x max cable length) ÷
Number of pairs used for power supply line (1)

Applying the conditions in the above table to formula (1) gives the following result.

$$(4.95 - (4.5 + 0.035)) [V] \geq (0.27 [A] \times a [\Omega/m] \times 2 \times L [m]) \div b [wires] \quad (2)$$

Modify formula (2) above to the following one.

$$L [m] \leq \frac{b (4.95 - 4.535)}{0.54 a} \quad (3)$$

Produce the feedback cable of the max cable length (L[m]), wire resistance of used wire material (a[Ω/m]) and Number of pairs used for power supply line (b[wires]) satisfying formula (3) above.

4.4.4 Wiring with NC Device (Example)

The "Signal cable" and the "Connector on the signal cable" in the table below indicate the connection in the case D-sub connectors are used.

If other connectors were to be used, the connection shall be performed by the user.

When the signal cable is a discrete one, and in the case not using a feedback cable, refer to 4.2.1 Output Signal" on page 34 to connect the lead wire directly to the connector on the NC device.

Follow the connection method recommended by the manufacturer of the connector.



Make sure to ground the metal shield of the feedback cable to the ground bar, etc. immediately in front of the NC device.

Tips

Specifications of recommended cable material for feedback cables (A66L-0001-0286):

- Wire material for power supply: 0.5 mm² three black wires, three red wires
- Wire material for signal: 0.18 mm² Twisted pair wire (black × red, black × white, red × white)

AT135* (interface specifications: manufactured by FANUC Corporation)

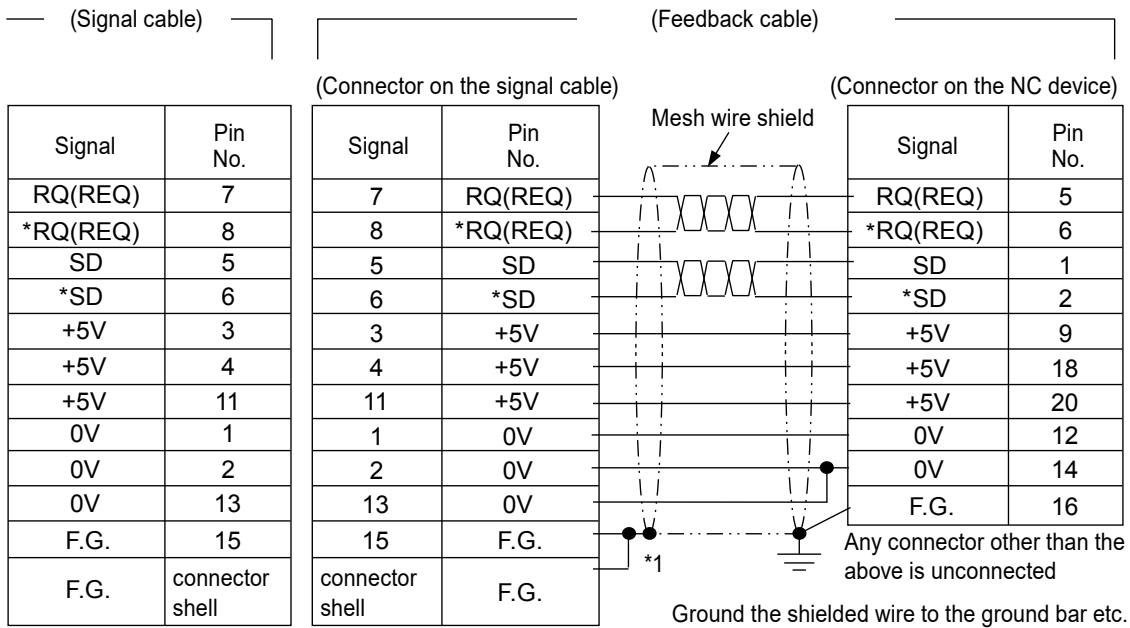

NOTICE

*1:
When a drain wire is attached to the metal shield, connect it to the 15th pin of the D sub connector.

■ AT134* (interface specifications: manufactured by Mitsubishi Electric Corporation)

● CNC 700 series connection

Corresponding servo-amplifier: MDS-D, MDS-DH, MDS-Dn

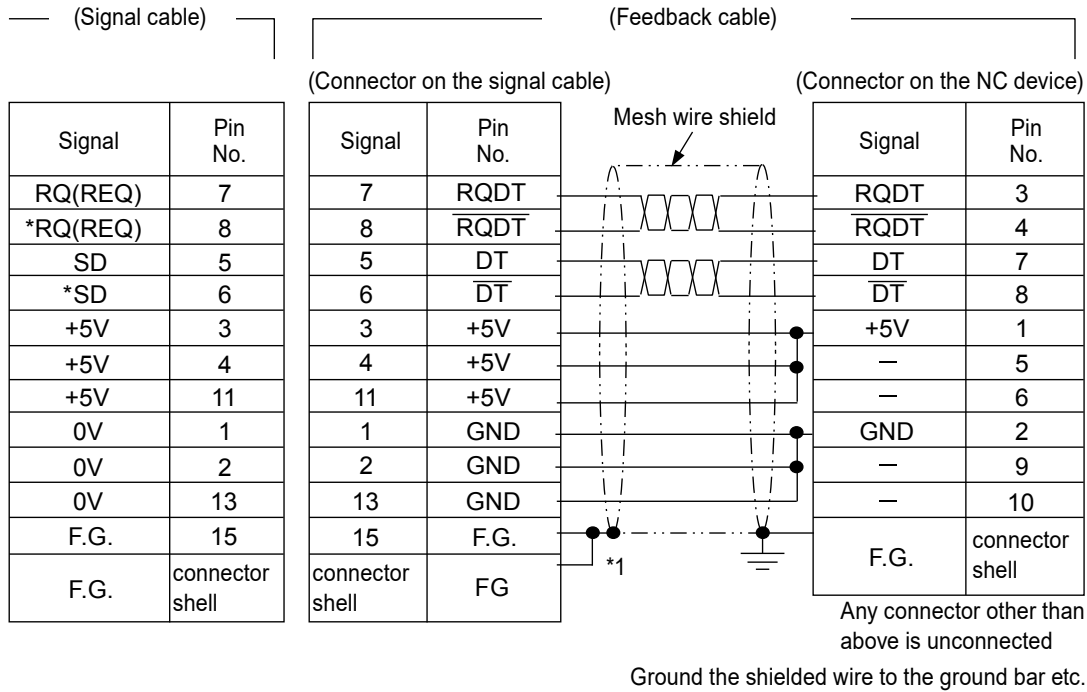

NOTICE

*1:
When a drain wire is attached to the metal shield, connect it to the 15th pin of the D sub connector.

■ AT130*A (interface specifications: manufactured by Mitutoyo ENSIS)

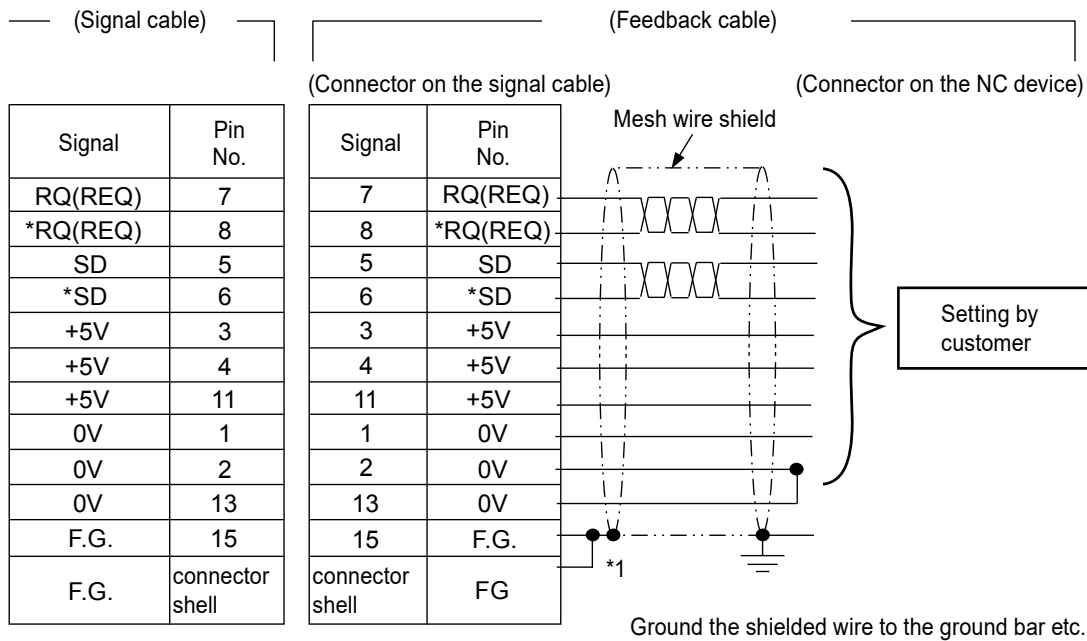

NOTICE

*1:
When a drain wire is attached to the metal shield, connect it to the 15th pin of the D sub connector.

■ AT138*A (interface specification: manufactured by YASKAWA Electric Corporation)

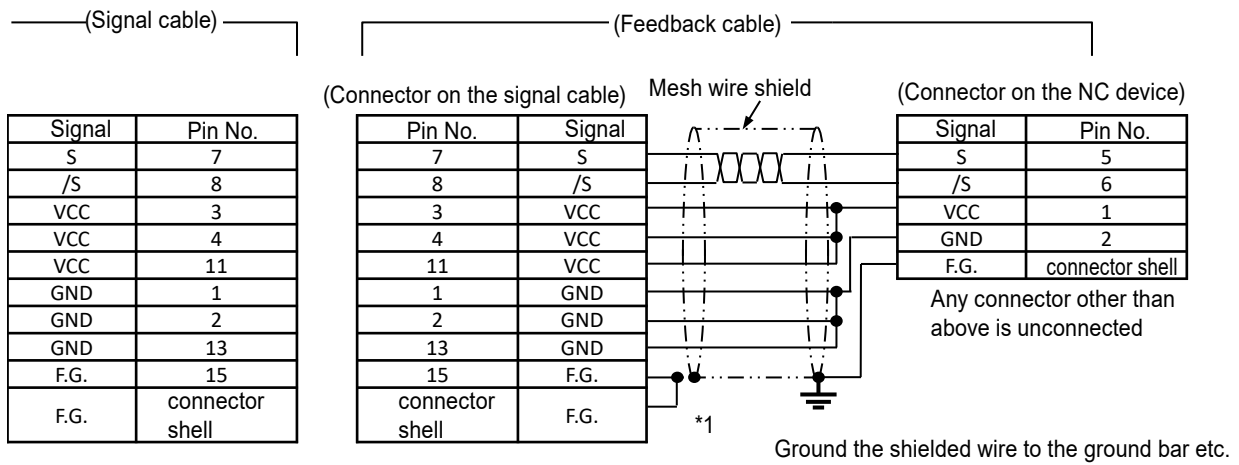

NOTICE

*1:
When a drain wire is attached to the metal shield, connect it to the 15th pin of the D sub connector.

4.5 Alarm Detection Function

This product is equipped with various alarm detection functions inside the Detector.

4.5.1 Alarm Detection Function

Alarms can be categorized into two groups: Caution and Error.

The cautions indicate low-level signal intensity or the temperature error inside the Detector. In those cases, once troubleshoot the causes, the normal state can be restored.

As for the errors, signal intensity errors or absolute values detection errors, etc. are detected. Once these errors occur, the error detection state will be maintained until they are reset, or the power is re-supplied.

<<List of alarm detections>>

Alarm type		Description
Caution	Signal intensity alarm	It is output when the signal strength of the scale is excessive or too small. * When the signal strength returns to the predetermined range, the alarm is canceled.
	Thermal alarm	An alarm is output as a warning when the temperature inside the Detector rises above 65 °C. * There is no error in the position data, but continuing to use it may cause a malfunction. * Review the usage conditions or the installation environment.
Error	Signal strength error	This signal is output when the signal strength of the scale is excessive or too small and there is a possibility of abnormality in the output data.
	Absolute value detection error	It is output when absolute position cannot be detected.
	Absolute value combination error	It is output when an error occurs in the combination of absolute positions.
	Hardware error	It is output when abnormality occurs in self-diagnosis.
	Initialization error	It is output when an error cause occurs during initialization immediately after turning on the power.
	Overspeed error	It is output when the speed exceeding specification occurs.

4.5.2 Alarm Code Content

This section describes the alarm code, their causes and remedies for each company interface.

■ For models compatible with FANUC Corporation

The table below shows the relationship between the ABS AT1300 alarm and the alarm code displayed on the servo amplifier made by FANUC Corporation. Note that the alarm code differs between alarm code of NC device when using scale with fully closed control and when using scale with linear motor.

Servo alarm Alarm code	Description	Cause and Remedy
LED error <ul style="list-style-type: none"> • During fully closed connection => 380 • During linear motor => 365 	Scale error occurred <ul style="list-style-type: none"> • Hardware error 	<<Cause>> <ul style="list-style-type: none"> • The scale detected an error. <<Remedy>> <ul style="list-style-type: none"> • Turn on the power again. • If an error is detected again, it is necessary to replace the scale unit.
Phase error <ul style="list-style-type: none"> • During fully closed connection => 381 • During linear motor => 361 	Scale error occurred <ul style="list-style-type: none"> • Signal strength error • Signal intensity alarm • Absolute value detection error • Absolute value combination error • Initialization error • Overspeed error 	<<Cause>> <ul style="list-style-type: none"> • The scale detected an error. <<Remedy>> <ul style="list-style-type: none"> • Check the mechanical fixing state of the scale. • Check the power supplied to the scale (power ripple noise) and electrical noises. • If there is no defect in the mounting condition or the power-related state, the scale unit needs to be replaced.
Serial data Error <ul style="list-style-type: none"> • During fully closed connection => 385 • During linear motor => 368 	Communication error occurred <ul style="list-style-type: none"> • No response 	<<Cause>> <ul style="list-style-type: none"> • An error occurred in which data from the scale could not be received due to communication between the scale and the NC device. (No response) <<Remedy>> <ul style="list-style-type: none"> • Check the connections of cables and connectors. • Check the routing of the cable (influence of noise such as large current cable).
Data transfer error <ul style="list-style-type: none"> • During fully closed connection => 386 • During linear motor => 369 	Communication error occurred <ul style="list-style-type: none"> • Communication error 	<<Cause>> <ul style="list-style-type: none"> • A CRC error and a stop bit error occurred in the serial data from the scale in communication between the scale and the NC device. (Communication error) <<Remedy>> <ul style="list-style-type: none"> • Check the routing of the cable (influence of noise such as large current cable).

Servo alarm Alarm code	Description	Cause and Remedy
Hardware disconnection alarm <ul style="list-style-type: none"> • During fully closed connection => 447 • During linear motor => 446 	Communication error occurred <ul style="list-style-type: none"> • Cable disconnection 	<<Cause>> <ul style="list-style-type: none"> • An error caused by cable disconnection occurred in communication between the scale and the NC device. <<Remedy>> <ul style="list-style-type: none"> • Check the connections of cables and connectors.

* The NC device alarm code is common to the α interface and α i interface of FANUC interface specification for position detection.

■ For models compatible with Mitsubishi Electric Corporation

The table below shows the relationship between the ABS AT1300 alarm and the alarm code displayed on the servo amplifier made by Mitsubishi Electric Corporation.

Servo alarm Alarm code	Description	Cause and Remedy
<ul style="list-style-type: none"> • AL2A 	Scale error occurred <ul style="list-style-type: none"> • Signal strength error • Absolute value detection error • Absolute value combination error • Hardware error • Initialization error • Overspeed error 	<<Cause>> <ul style="list-style-type: none"> • The scale detected an error. <<Remedy>> <ul style="list-style-type: none"> • Check the mechanical fixing state of the scale. • Check the power supplied to the scale (power ripple noise) and electrical noises. • If there is no defect in the mounting condition or the power-related state, the scale unit needs to be replaced.
<ul style="list-style-type: none"> • AL28 	Scale alarm occurred <ul style="list-style-type: none"> • Signal intensity alarm • Thermal alarm 	<<Cause>> <ul style="list-style-type: none"> • The scale detected a caution. The position data is correct; however, it is necessary to check the fixing state and the operating condition. <<Remedy>> <ul style="list-style-type: none"> • Check the mechanical fixing state of the scale. • Is the ambient temperature of the Detector over 60 °C? => In case of high temperature, it is necessary to review the operation conditions (speed, acceleration).

Servo alarm Alarm code	Description	Cause and Remedy
<ul style="list-style-type: none"> • AL16 	<p>Communication error occurred (during servo amplifier initialization)</p> <ul style="list-style-type: none"> • When an error is received consecutively three times on the servo amplifier side (including no response) 	<p><<Cause>></p> <ul style="list-style-type: none"> • Communication error between scale and servo amplifier occurred. (Communication impossible from the time of turning on the servo amplifier) <p><<Remedy>></p> <ul style="list-style-type: none"> • Check the connections of cables and connectors. • Check the routing of the cable (influence of noise such as large current cable).
<ul style="list-style-type: none"> • AL20 	<p>Communication error occurred (during servo amplifier control)</p> <ul style="list-style-type: none"> • When an error is received consecutively three times on the servo amplifier side (including no response) 	<p><<Cause>></p> <ul style="list-style-type: none"> • Communication error between scale and servo amplifier occurred. (Occurred while controlling by the servo amplifier) <p><<Remedy>></p> <ul style="list-style-type: none"> • Check the connections of cables and connectors. • Check the routing of the cable (influence of noise such as large current cable).

■ For models compatible with Yasukawa Corporation

The table below shows the relationship between the ABS AT1300 alarm and the alarm code displayed on the servo amplifier made by Yasukawa Electric Corporation.

Servo alarm Alarm code	Description	Cause and Remedy
<ul style="list-style-type: none"> • A.8A3 *1 • A.84U *2 	<p>Scale error occurred</p> <ul style="list-style-type: none"> • Signal intensity error • Absolute value detection error • Absolute value combination error • Initialization error 	<p><<Cause>></p> <ul style="list-style-type: none"> • The scale detected an error. <p><<Remedy>></p> <ul style="list-style-type: none"> • Check the mechanical fixing state of the scale. • Check the power supplied to the scale (power ripple noise) and electrical noises. • If there is no defect in the mounting condition or the power-related state, the scale unit needs to be replaced. .
<ul style="list-style-type: none"> • A.8A5 *1 • A.85U *2 	<p>Scale error occurred</p> <ul style="list-style-type: none"> • Overspeed error 	<p><<Cause>></p> <ul style="list-style-type: none"> • The scale detected an overspeed error. <p><<Remedy>></p> <ul style="list-style-type: none"> • Review the driving condition (command speed).

4 Specifications

Servo alarm Alarm code	Description	Cause and Remedy
<ul style="list-style-type: none"> • A.8A6 *1 • A.860 *2 	<p>Scale alarm occurred</p> <ul style="list-style-type: none"> • Thermal alarm • Signal intensity alarm 	<p><<Cause>></p> <ul style="list-style-type: none"> • The scale detected a caution. The position data is correct; however, it is necessary to check the fixing state and the operating condition. <p><<Remedy>></p> <ul style="list-style-type: none"> • Check the mechanical fixing state of the scale. • Is the ambient temperature of the Detector over 60 °C? => In case of high temperature, it is necessary to review the operation conditions (speed, acceleration).
<ul style="list-style-type: none"> • A.8A1 *1 • A.891 *2 	<p>Scale error occurred</p> <ul style="list-style-type: none"> • Hardware error 	<p><<Cause>></p> <ul style="list-style-type: none"> • The scale detected an error. <p><<Remedy>></p> <ul style="list-style-type: none"> • The scale needs to be replaced.
<ul style="list-style-type: none"> • A.CF1 *1 • C90 *2 	<p>Communication error occurred (during servo amplifier control)</p>	<p><<Cause>></p> <ul style="list-style-type: none"> • Communication error between scale and servo amplifier occurred. (Occurred while controlling by the servo amplifier) <p><<Remedy>></p> <ul style="list-style-type: none"> • Check the connections of cables and connectors. • Check the routing of the cable (influence of noise such as large current cable).

*1 When using the scale with fully closed control

*2 When using scale with linear motor

4.6 Air Purging

There is a method to improve environmental resistance (coolant resistance, dust resistance) of assembly type linear scale by supplying clean compressed air into the scale main unit. Set up pipe to one of the M5 screw holes on both sides of the scale main unit and supply compressed air.

NOTICE

- Air supply is an auxiliary method for cleaning inside the scale main unit.
- For air supply, mounting posture is important. Follow the instructions in this manual.
- When supplying air, it is necessary to periodically replace the air filter due to the contamination of the air source. If you continue to use the dirty filter, dirt will enter the scale and cause trouble, so pay attention to this issue.

4.6.1 Input Air Specification

The table below shows the input air specification.

This specification corresponds to ISO8573-1 Class 1.4.1.

Items	Specifications
Maximum particle diameter (μm)	0.1
Lowest pressure dew point ($^{\circ}\text{C}$)	+3
Oil concentration (mg/m^3)	0.01

4.6.2 Air Flow Supplied to the Scale

Supply air of 10 L/min–20 L/min per scale axis.

Air should slightly come out from the closed part of the dust-proof rubber lips.

Adjust the air flow referring to the table below.

Conditions	Air flow rate
Using Mitutoyo's fixed diaphragm (ID: $\varnothing 0.9$)	<p>Make adjustment with the air pressure, so that the air flow becomes 10 L/min–20 L/min (per scale unit).</p> <p>Reference values when supplying air to one axis are as follows.</p> <ul style="list-style-type: none"> • If air pressure is 0.1 MPa: approx. 12.7 L/min • If air pressure is 0.2 MPa: approx. 19 L/min
Using other fixed diaphragms	<p>Make adjustment with the air pressure, so that the air flow becomes 10 L/min–20 L/min (per scale unit).</p> <p>For information on the air flow and pressure relationships, refer to the flow characteristics (ID of the fixed diaphragm and flow-pressure relations) provided by each pneumatic component manufacturer.</p>

4 Specifications

Using flow rate adjustable valves	<p>Make adjustment with the air pressure, so that the air flow becomes 10 L/min–20 L/min (per scale unit).</p> <div style="border: 1px solid black; padding: 5px; margin: 10px 0;"> <p>NOTICE</p> </div> <p>Make sure not to supply a large amount of air before making adjustments. Otherwise, it may cause components to break thereby resulting in malfunctions.</p>
-----------------------------------	--



4.6.3 Air Supply Unit

The specifications for recommended air devices and the manufacturer models are described in the following.

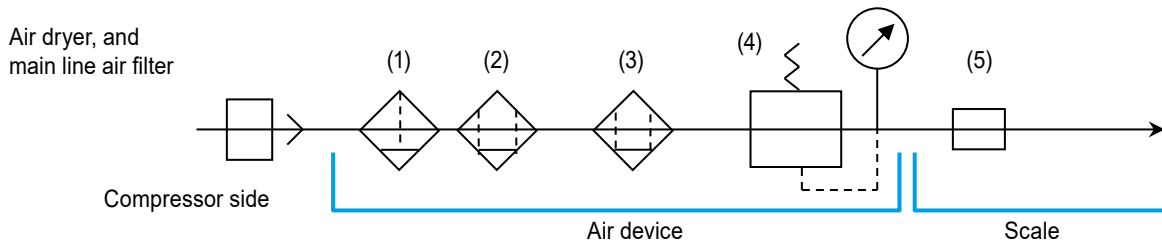

If the specifications are the same, you can use air equipment made by another company.

Estimated time of element replacement for each filter is one year.



No.	Component	Appearance	Specifications	Part No.	
				Part No. (Mitutoyo)	Manufacturer Model
(1)	Air filter		<ul style="list-style-type: none"> Fluid: Compressed air Maximum operating pressure: 1.0 MPa Proof pressure: 1.5 MPa Maximum particle diameter (filtration): 5 μm Secondary oil concentration: - 	-	F1000-8-W (CKD)
(2)	Oil mist filter		<ul style="list-style-type: none"> Fluid: Compressed air Maximum operating pressure: 1.0 MPa Proof pressure: 1.5 MPa Maximum particle diameter (filtration): 0.01 μm Secondary oil concentration: 0.01 mg/m³ or below Element replacement: one year (6000 hours) or when pressure is lowered to 0.1 MPa or lower 	-	M1000-8-W (CKD)

4 Specifications

(3)	High performance oil mist filter		<ul style="list-style-type: none"> • Fluid: Compressed air • Maximum operating pressure: 1.0 MPa • Proof pressure: 1.5 MPa • Maximum particle diameter (filtration): 0.01 μm • Secondary oil concentration: 0.001 mg/m³ or below • Element replacement: one year (6000 hours) or when pressure is lowered to 0.1 MPa or lower 	-	MX1000-8-W (CKD)
(4)	Regulator		<ul style="list-style-type: none"> • Fluid: Compressed air • Maximum operating pressure: 1.0 MPa • Proof pressure: 1.5 MPa • Set pressure range: 0.1 MPa–0.7 MPa • Oil proof treatment type 	-	RA-050-L (CKD)
(5)	Fixed diaphragm		<ul style="list-style-type: none"> • Fluid: Air • Set pressure range: 0.1 MPa–0.9 MPa • Screw tightening torque: 1.0 N·m–1.5 N·m • Flow rate at pressure 0.1 MPa: Approx. 12.7 L/min (per axis) • Flow rate at pressure 0.2 MPa: Approx. 19 L/min (per axis) 	06ACJ155	PC6-M5M-0.9 (Pisco custom order)
(1) to (4)	Air unit	See the next figure.	<p>Equivalent to ISO-8573-1 Class 1.4.1</p> <ul style="list-style-type: none"> • Maximum particle diameter (filtration): 0.01 μm • Lowest pressure dew point: - • Oil concentration (oil mist concentration): 0.001 mg/m³ or less • Flow rate at pressure 0.1 MPa: 12.7 L/min (per axis) • Insertable flow rate (maximum): 75 L/min • When to replace each element: 1 year 	06ACJ154	-

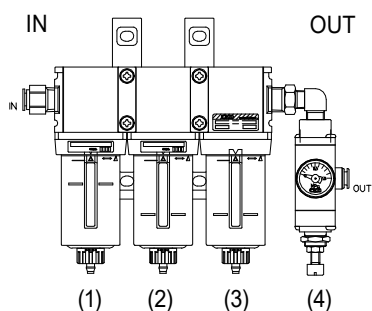

- (1) Air filter
- (2) Oil mist filter
- (3) High performance oil mist filter
- (4) Regulator

Appearance of air unit

4.6.4 Connection Method

Do not directly supply air from the compressor to the air unit. Make sure to use dry compressed air through the air dryer or main line air filter.

Attach the fixed diaphragm to the scale side.

■ When supplying air to two linear scales (2 axes)

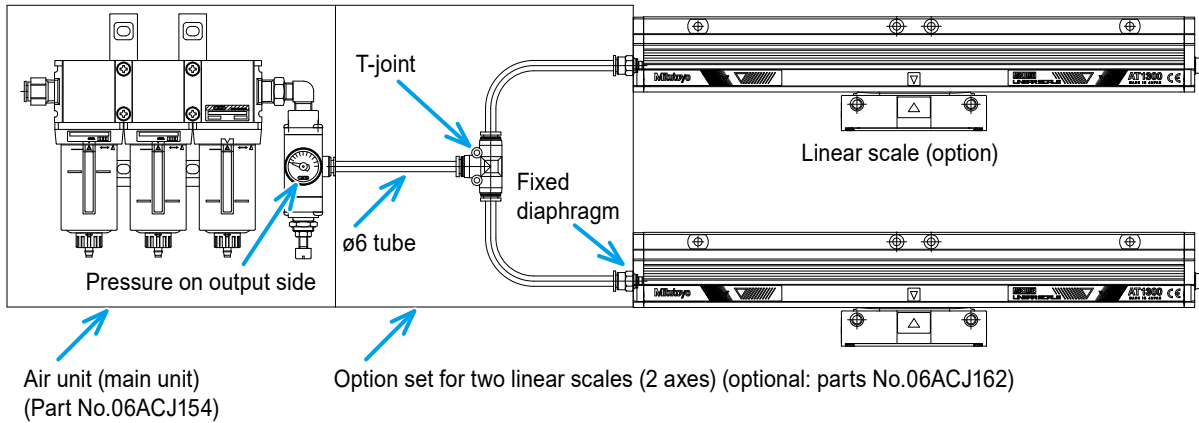

■ When supplying air to three linear scales (3 axes)

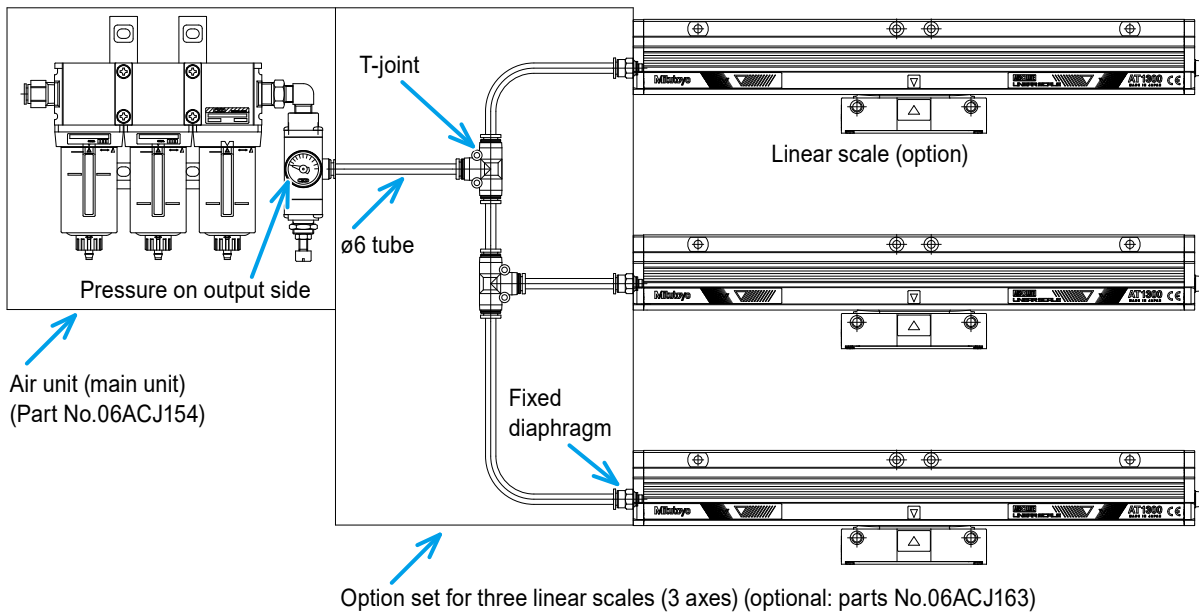

Tips

- For each air unit, air can be supplied up to five axes.
- You can connect up to four to five axes by combining option sets for two axes (No.06ACJ162) and three axes (No.06ACJ163).
A ø6 air tube (length: 20 m) is included in each option set.
- An estimate of the element replacement period for parts No.06ACJ159, 06ACJ160, 06ACJ161 is one year.
The time of replacement differs according to the operating conditions.
- For information on maintenance, refer to the manual supplied with the unit.

4.7 External View and Dimensional Drawings of the Scale Main Unit

4.7.1 ABS AT1300-H (High Precision Specification)

Dimensional drawings

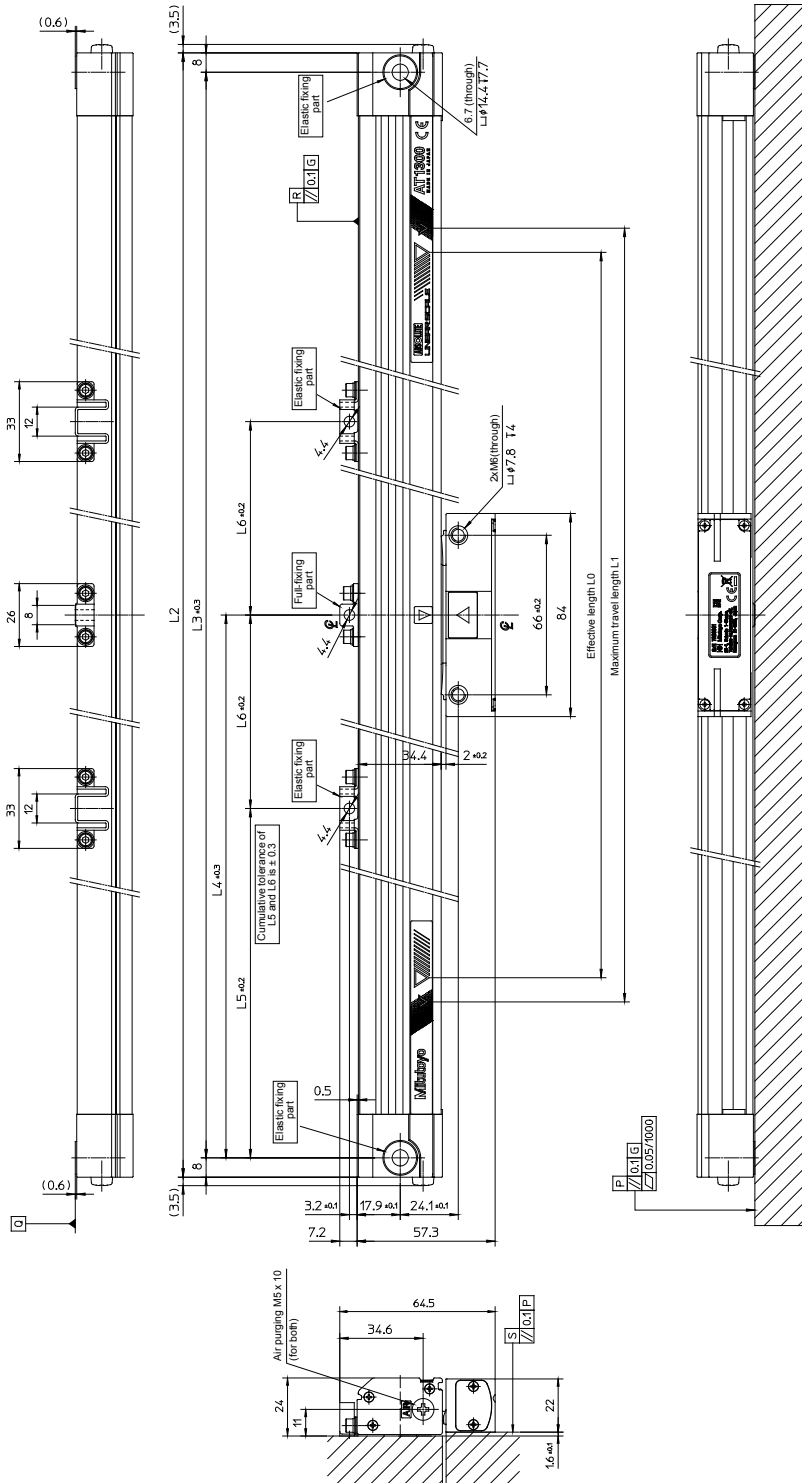

4 Specifications

Tips

- G represents the machine guide.
- P represents the opposite side of the aluminum frame mounting surface. Also, S represents the opposite side of the Detector mounting surface.
- Q and R represent the linear scale's reference surfaces for mounting.
- For descriptions L_0 to L_6 in the figure, refer to the next section.

■ Dimensional Drawings

Unit: mm

Effective length L_0	Maximum travel distance L_1	Full length L_2	Mounting pitch L_3	L_4	L_5	L_6
100	120	265	249	124.5		
150	170	315	299	149.5		
200	220	365	349	174.5		
250	270	415	399	199.5		
300	320	465	449	224.5		
350	370	515	499	249.5		
400	420	565	549	274.5		
450	470	615	599	299.5		
500	520	665	649	324.5		
600	620	765	749	(374.5)		
700	720	865	849	(424.5)	224.5	200
750	770	915	899	(449.5)	224.5	225
800	820	965	949	(474.5)	244.5	230
900	920	1065	1049	(524.5)	264.5	260
1000	1020	1165	1149	(574.5)	284.5	290

4.7.2 ABS AT1300-S (High Rigidity Specification)

■ Dimensional drawings

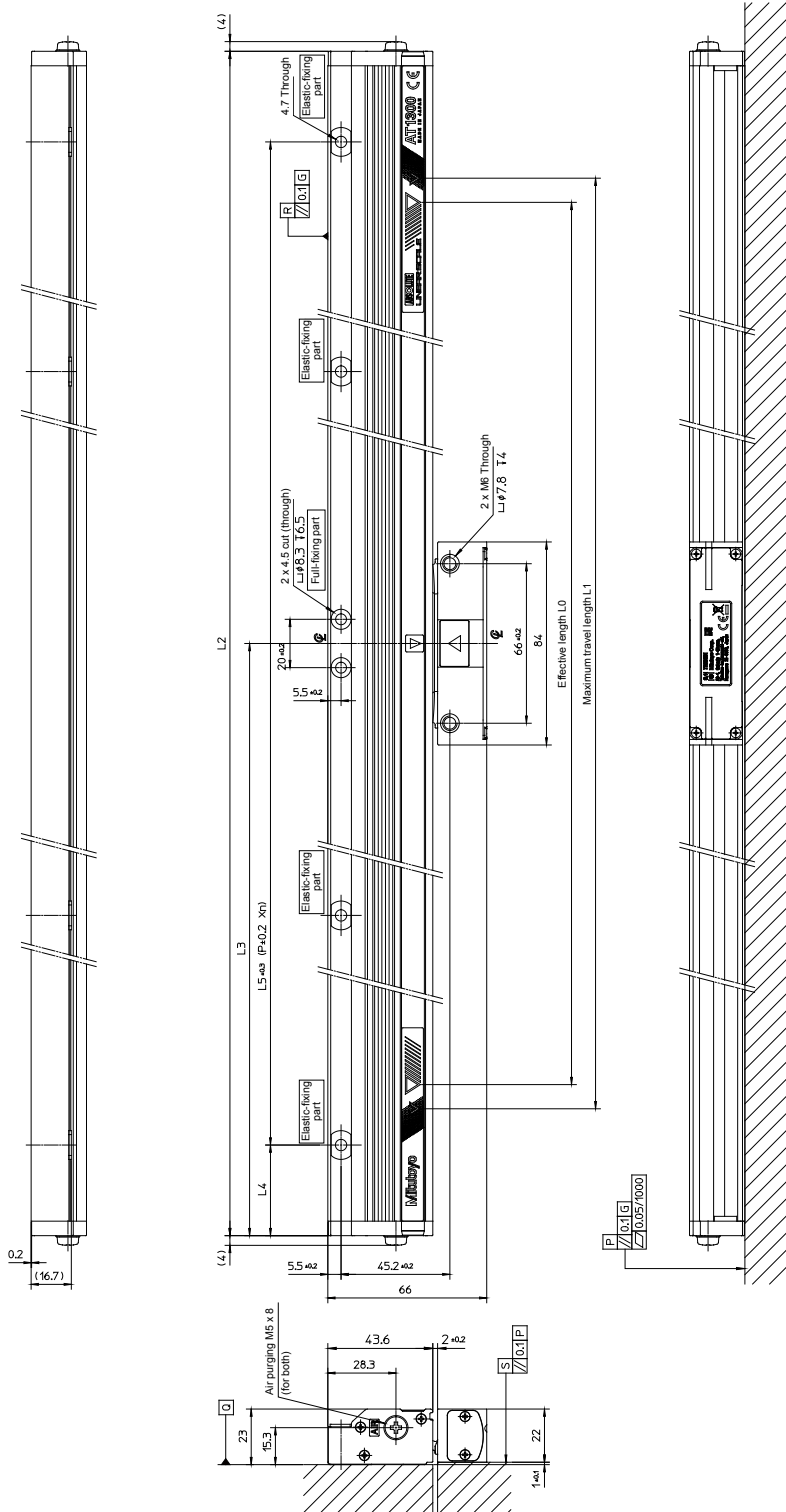

4 Specifications

NOTICE

- G represents the machine guide.
- P represents the opposite side of the scale main unit. Also, S represents the opposite side of the Detector mounting surface.
- Q and R represent the linear scale unit's reference surfaces for mounting.
- For descriptions of L0 to L5, P, and n in the figure, refer to the next section.

■ Dimensional drawings table

Unit of L0 to L5 and P: mm

Effective length L_0	Maximum travel distance L_1	Full length L_2	L_3	L_4	L_5	P	n
100	120	225	112.5	37.5	150	75	2
200	220	325	162.5	37.5	250	125	2
300	320	425	212.5	37.5	350	175	2
400	420	525	262.5	62.5	400	200	2
500	520	625	312.5	62.5	500	125	4
600	620	725	362.5	62.5	600	150	4
700	720	825	412.5	62.5	700	175	4
800	820	925	462.5	62.5	800	200	4
900	920	1025	512.5	62.5	900	150	6
1000	1020	1125	562.5	37.5	1050	175	6
1100	1120	1225	612.5	87.5	1050	175	6
1200	1220	1325	616.5	62.5	1200	200	6
1300	1320	1425	712.5	112.5	1200	150	8
1400	1420	1525	762.5	62.5	1400	175	8
1500	1520	1625	812.5	112.5	1400	175	8
1600	1620	1725	862.5	62.5	1600	200	8
1800	1820	1925	962.5	87.5	1750	175	10
2000	2020	2125	1062.5	62.5	2000	200	10
2200	2220	2325	1162.5	112.5	2100	175	12

MEMO

5 Troubleshooting

This chapter describes how to check for the reasons why problems occur when initially powering on, or for when alarms are generated during operation.

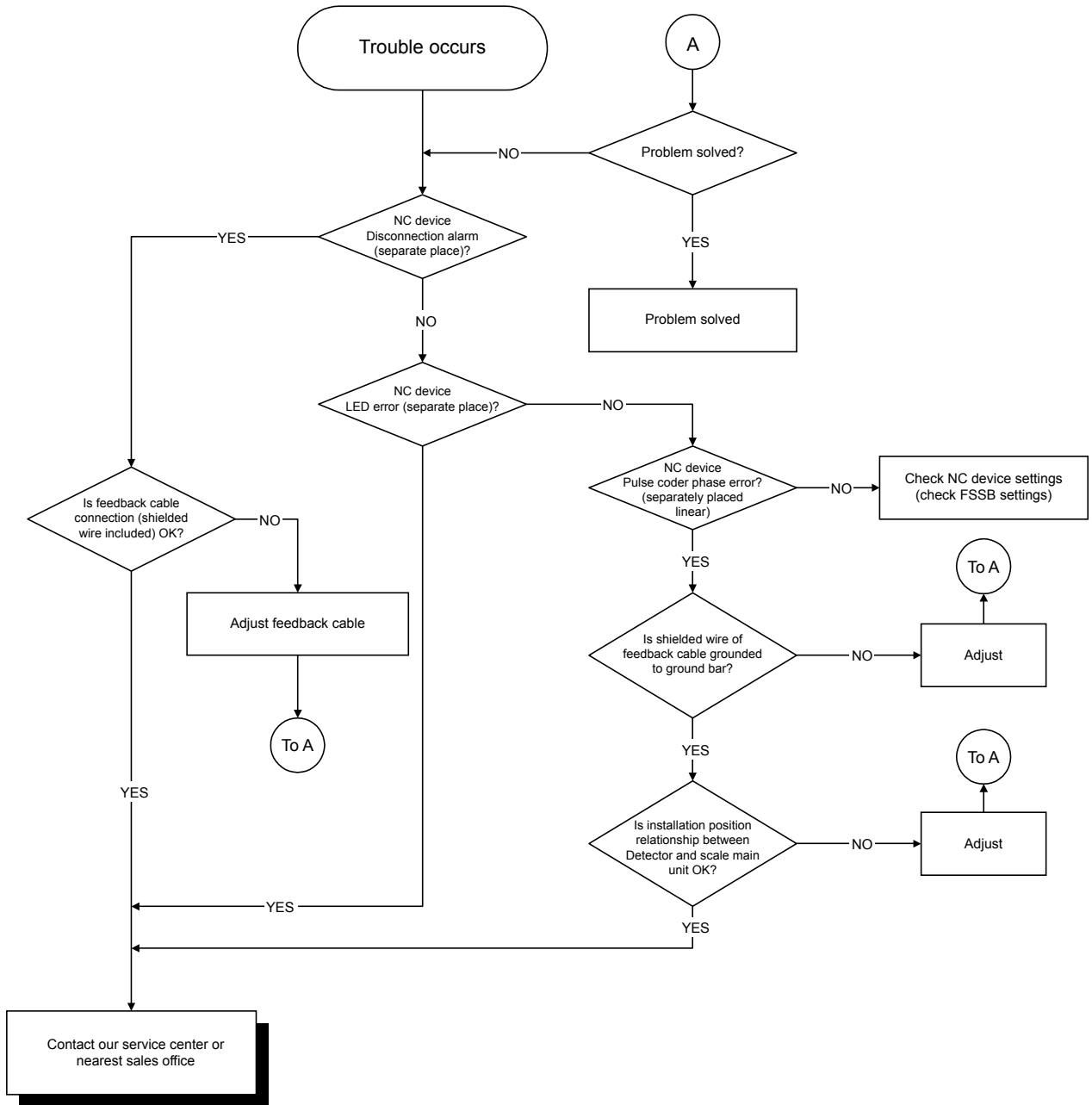

Tips





We provide software which makes it possible for the user to initially judge failure/error of this product. For details, contact a Mitutoyo sales office/service center.

MEMO

6 Appendix

6.1 Quantity of the Supplied Accessories for Installation

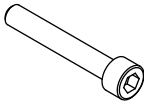
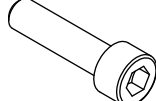
6.1.1 ABS AT1300-H (High Precision Specification)



Effective length	Hex socket head cap screw M4 x 10 	Hex socket head cap screw M4 x 16 	Spring washer, nominal 4 	Hex socket head cap screw M4 x 25 	Hex socket head cap screw M6 x 25 	Spring washer, nominal 6 
100	2	1	3	2	2	2
150	2	1	3	2	2	2
200	2	1	3	2	2	2
250	2	1	3	2	2	2
300	2	1	3	2	2	2
350	2	1	3	2	2	2
400	2	1	3	2	2	2
450	2	1	3	2	2	2
500	2	1	3	2	2	2
600	2	1	3	2	2	2
700	2	1	3	2	2	2
750	2	1	3	2	2	2
800	2	1	3	2	2	2
900	2	1	3	2	2	2
1000	2	1	3	2	2	2

Details of usage quantities are as follows:

 "ABS AT1300-H (high precision specification)" in "3.2.2 Mounting the Scale Main Unit's" (page 18)

 "3.3.1 Installing the Detector" (page 24)

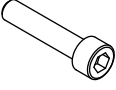
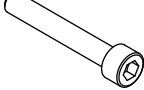
6.1.2 ABS AT1300-S (High Rigidity Specification)

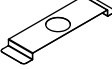
Effective length	Hex socket head cap screw M4 x 16 	Hex socket head cap screw M4 x 25 	Spring washer, nominal 4 Small round 	Plain washer, nominal 4 Small round 	Dedicated leaf spring 
100	4	8	12	12	6
200	4	8	12	12	6
300	4	8	12	12	6
400	4	8	12	12	6
500	4	8	12	12	6
600	4	8	12	12	6
700	4	8	12	12	6
800	4	8	12	12	6
900	4	8	12	12	6
1000	4	8	12	12	6
1100	4	8	12	12	6
1200	4	8	12	12	6
1300	4	14	18	18	12
1400	4	14	18	18	12
1500	4	14	18	18	12
1600	4	14	18	18	12
1800	4	14	18	18	12
2000	4	14	18	18	12
2200	4	14	18	18	12

Details of usage quantities are as follows:

 "ABS AT1300-S (high rigidity specification)" in "3.2.2 Mounting the Scale Main Unit's" (page 21)

 "3.3.1 Installing the Detector" (page 24)

SERVICE NETWORK

*As of February 2021

Europe

Mitutoyo Europe GmbH

Borsigstrasse 8-10, 41469 Neuss, GERMANY
TEL: 49 (0)2137 102-0 FAX: 49 (0)2137 102-351

Mitutoyo CTL Germany GmbH

Von-Gunzert-Strasse 17, 78727 Oberndorf, GERMANY
TEL: 49 (0)7423 8776-0 FAX: 49 (0)7423 8776-99

KOMEG Industrielle Messtechnik GmbH

Zum Wasserwerk 3, 66333 Völklingen, GERMANY
TEL: 49 (0)6898 91110 FAX: 49 (0)6898 911100

Germany

Mitutoyo Deutschland GmbH

Borsigstrasse 8-10, 41469 Neuss, GERMANY
TEL: 49 (0)2137 102-0 FAX: 49 (0)2137 86 85

M³ Solution Center Hamburg

Tempowerkring 9-im HIT-Technologiepark 21079
Hamburg, GERMANY
TEL: 49 (0)40 791894-0 FAX: 49 (0)40 791894-50

M³ Solution Center Berlin

Ernst-Lau-Straße 6, 12489 Berlin, GERMANY
TEL:49(0)30 2611 267 FAX: 49 30 67988729

M³ Solution Center Eisenach

Neue Wiese 4, 99817 Eisenach,GERMANY
TEL: 49 (0)3691 88909-0 FAX: 49 (0)3691 88909-9

M³ Solution Center Ingolstadt

Marie-Curie-Strasse 1A, 85055 Ingolstadt, GERMANY
TEL: 49 (0)841 954920 FAX: 49 (0)841 9549250

M³ Solution Center Leonberg

Steinbeisstrasse 2, 71229 Leonberg, GERMANY
TEL: 49 (0)7152 6080-0 FAX: 49 (0)7152 608060

Mitutoyo-Messgeräte Leonberg GmbH

Heidenheimer Strasse 14, 71229 Leonberg, GERMANY
TEL: 49 (0)7152 9237-0 FAX: 49 (0)7152 9237-29

U.K.

Mitutoyo (UK) Ltd.

Joule Road, West Point Business Park,
Andover, Hampshire SP10 3UX, UNITED KINGDOM
TEL: 44 (0)1264 353 123 FAX: 44 (0)1264 354883

M³ Solution Center Coventry

Unit6, Banner Park, Wickmans Drive, Coventry,
Warwickshire CV4 9XA, UNITED KINGDOM
TEL: 44 (0)2476 426300 FAX: 44 (0)2476 426339

M³ Solution Center Halifax

Lowfields Business Park, Navigation Close, Elland,
West Yorkshire HX5 9HB, UNITED KINGDOM
TEL: 44 (0)1422 375566 FAX: 44 (0)1422 328025

M³ Solution Center East Kilbride

The Baird Building, Rankine Avenue, Scottish
Enterprise Technology Park, East Killbride G75
0QF, UNITED KINGDOM
TEL: 44 (0)1355 581170 FAX: 44 (0)1355 581171

France

Mitutoyo France

Paris Nord 2-123 rue de la Belle Etoile, BP 59267
ROISSY EN FRANCE 95957 ROISSY CDG
CEDEX, FRANCE
TEL: 33 (0)149 38 35 00

M³ Solution Center LYON

Parc Mail 523, cours du 3ème millénaire, 69791
Saint-Priest, FRANCE
TEL: 33 (0)149 38 35 70

M³ Solution Center STRASBOURG

Parc de la porte Sud, Rue du pont du péage,
67118 Geispolsheim, FRANCE
TEL: 33 (0)149 38 35 80

M³ Solution Center CLUSES

Espace Scionzier 480 Avenue des Lacs, 74950
Scionzier, FRANCE
TEL: 33 (0)1 49 38 35 90

M³ Solution Center TOULOUSE

Aeroparc Saint Martin Cellule B08 ZAC de Saint
Martin du Touch 12 rue de Caulet 31300
Toulouse, FRANCE
TEL: 33 (0)1 49 38 42 90

M³ Solution Center RENNES

2, rue Claude Chappe, PA le Vallon - ZAC
Mivoie, 35230 Noyal-Châtillon-sur-Seiche,
FRANCE
TEL: 33 (0)1 49 38 42 10

Italy

MITUTOYO ITALIANA S.r.l.

Corso Europa, 7 - 20045 Lainate (MI), ITALY
TEL: 39 02 935781 FAX: 39 02 93578255

M³ Solution Center BOLOGNA

Via dei Carpini1/A - 40011 Anzola Emilia (BO), ITALY
TEL: 39 02 93578215 FAX: 39 02 93578255

M³ Solution Center CHIETI

Contrada Santa Calcagna - 66020 Rocca S. Giovanni (CH), ITALY
TEL: 39 02 93578280 FAX: 39 02 93578255

M³ Solution Center PADOVA

Via G. Galilei 21/F - 35035 Mestrino (PD), ITALY
TEL: 39 02 93578268 FAX: 39 02 93578255

Netherlands

Mitutoyo Nederland B.V.

Wiltonstraat 25, 3905 KW Veenendaal,
THE NETHERLANDS
TEL: 31(0)318-534911

Mitutoyo Nederland B.V. / M³ Solution Center Enschede

Institutenweg 50, 7521 PK Enschede,
THE NETHERLANDS
TEL: 31(0)318-534911

Mitutoyo Nederland B.V. / M³ Solution Center Eindhoven

De Run 1115, 5503 LB Veldhoven,
THE NETHERLANDS
TEL: 31(0)318-534911

Mitutoyo Research Center Europe B.V.

De Rijn 18, 5684 PJ Best, THE NETHERLANDS
TEL:31(0)499-320200 FAX:31(0)499-320299

Belgium

Mitutoyo Belgium N.V. / M³ Solution Center Melsele

Schaarbeekstraat 20, B-9120 Melsele, BELGIUM
TEL: 32 (0)3-2540444

Sweden

Mitutoyo Scandinavia AB

Släntvägen 6, 194 61 Upplands Väsby, SWEDEN
TEL: 46 (0)8 594 109 50 FAX: 46 (0)8 590 924 10

M³ Solution Center Alingsås

Ängsvaktaregatan 3A, 441 38 Alingsås, SWEDEN
TEL: 46 (0)8 594 109 50 FAX:46 (0)322 63 31 62

M³ Solution Center Värnamo

Storgatsbacken 1, 331 30 Värnamo, SWEDEN
TEL: 46 (0)8 594 109 50 FAX: 46 (0)370 463 34

Switzerland

Mitutoyo (Schweiz) AG

Steinackerstrasse 35, 8902 Urdorf, SWITZERLAND
TEL: 41 (0)447361150 FAX: 41(0)447361151

Mitutoyo (Suisse) SA

Rue Galilée 4, 1400 Yverdon-les Bains, SWITZERLAND
TEL: 41 (0)244259422 FAX: 41 (0)447361151

Poland

Mitutoyo Polska Sp.z o.o.

Ul.Graniczna 8A, 54-610 Wroclaw, POLAND
TEL: 48 (0)71354 83 50 FAX: 48 (0)71354 83 55

Czech Republic

Mitutoyo Česko s.r.o.

Dubská 1626, 415 01 Teplice, CZECH REPUBLIC
TEL: 420 417-514-011 FAX: 420 417-579-867

Mitutoyo Česko s.r.o. M³ Solution Center Ivančice

Ke Karlovu 62/10, 664 91 Ivančice, CZECH REPUBLIC
TEL: 420 417-514-011 FAX: 420 417-579-867

Mitutoyo Česko s.r.o. M³ Solution Center Ostrava Mošnov

Mošnov 314, 742 51 Mošnov, CZECH REPUBLIC
TEL: 420 417-514-050 FAX:420 417-579-867

Mitutoyo Česko s.r.o. Slovakia Branch

Hviezdoslavova 124, 017 01 Povážská Bystrica, SLOVAKIA
TEL: 421 948-595-590

Hungary

Mitutoyo Hungária Kft.

Záhony utca 7, D-épület / fsz, 1031 Budapest, HUNGARY
TEL: 36 (0)1 2141447 FAX: 36 (0)1 2141448

Romania

Mitutoyo Romania SRL

1A Drumul Garii Odai Street, showroom, Ground Floor, 075100 OTOPENI-ILFOV, ROMANIA
TEL: 40 (0)311012088 FAX: +40 (0)311012089

Showroom in Brasov

Strada Ionescu Crum Nr.1, Brasov Business Park Turnul 1, Mezanin, 500446 Brasov-Judetul Brasov, ROMANIA
TEL/FAX: 40 (0)371020017

Russian Federation**Mitutoyo RUS LLC**

13 Sharikopodshipnikovskaya, bld.2,
115088 Moscow, RUSSIAN FEDERATION
TEL: 7 495 7450 752

Finland**Mitutoyo Scandinavia AB Finnish Branch**

Viherkiiitäjä 2A, 33960, Pirkkala, FINLAND
TEL: 358 (0)40 355 8498

Austria**Mitutoyo Austria GmbH**

Salzburger Straße 260 / 3 A-4600 Wels, AUSTRIA
TEL: 43 (0)7242 219 998

Mitutoyo Austria GmbH Goetzis Regional showroom

Lastenstrasse 48a 6840 Götzis AUSTRIA

Singapore**Mitutoyo Asia Pacific Pte. Ltd.****Head office / M³ Solution Center**

24 Kallang Avenue, Mitutoyo Building,
SINGAPORE 339415
TEL:(65)62942211 FAX:(65)62996666

Malaysia**Mitutoyo (Malaysia) Sdn. Bhd.****Kuala Lumpur Head Office / M³ Solution Center**

Mah Sing Integrated Industrial Park, 4, Jalan Utarid U5/14,
Section U5, 40150 Shah Alam, Selangor, MALAYSIA
TEL:(60)3-78459318 FAX:(60)3-78459346

Penang Branch office / M³ Solution Center

30, Persiaran Mahsuri 1/2, Sunway Tunas, 11900
Bayan Lepas, Penang, MALAYSIA
TEL:(60)4-6411998 FAX:(60)4-6412998

Johor Branch office / M³ Solution Center

70 (Ground Floor), Jalan Molek 1/28, Taman
Molek, 81100 Johor Bahru, Johor, MALAYSIA
TEL:(60)7-3521626 FAX:(60)7-3521628

Thailand**Mitutoyo(Thailand)Co., Ltd.****Bangkok Head Office / M³ Solution Center**

76/3-5, Chaengwattana Road, Kwaeng Anusaowaree,
Khet Bangkaen, Bangkok 10220, THAILAND
TEL:(66)2080 3500 FAX:(66)2521 6136

Chonburi Branch / M³ Solution Center

7/1, Moo 3, Tambon Bowin, Amphur Sriracha,
Chonburi 20230, THAILAND
TEL:(66)2080 3563 FAX:(66)3834 5788

ACC Branch / M³ Solution Center

122/8, 122/9, Moo 6, Tambon Donhuaroh, Amphur
Muangchonburi, Chonburi 20000, THAILAND
TEL:(66)2080 3565

Indonesia**PT. Mitutoyo Indonesia****Head Office / M³ Solution Center**

Jalan Sriwijaya No.26 Desa cibatu Kec. Cikarang
Selatan Kab. Bekasi 17530, INDONESIA
TEL: (62)21-2962 8600 FAX: (62)21-2962 8604

Vietnam**Mitutoyo Vietnam Co., Ltd****Hanoi Head Office / M³ Solution Center**

1st & 2nd floor, MHDl Building, No. 60 Hoang Quoc
Viet Road, Nghia Do Ward, Cau Giay District, Hanoi,
VIETNAM

TEL:(84)24-3768-8963 FAX:(84)24-3768-8960

Ho Chi Minh City Branch Office / M³ Solution Center

123 Dien Bien Phu Street, Ward 15, Binh Thanh
District, Ho Chi Minh City, VIETNAM

TEL:(84)28-3840-3489 FAX:(84)28-3840-3498

Philippines**Mitutoyo Philippines, Inc.****Head Office / M³ Solution Center**

Unit 1B & 2B LTI, Administration Building 1, Annex 1, North
Main Avenue, Laguna Technopark, Binan Laguna 4024,
PHILIPPINES

TEL:(63)49 544 0272 FAX:(63)49 544 0272

India**Mitutoyo South Asia Pvt. Ltd. Head Office**

C-122, Okhla Industrial Area, Phase-I,
New Delhi-110 020, INDIA

TEL:(91) 11-26372090 FAX: (91) 11-26372636

MSA Technical Center

Plot no. 65, Ground Floor, Udyog Vihar, Phase-4 Gurga-
on, Haryana - 122016, INDIA

TEL : (91) 124-2340286/287

Mumbai Region Head office

303, Sentinel Hiranandani Business Park Powai,
Mumbai-400 076, INDIA

TEL:(91) 22-25700684/837/839 FAX: (91) 22-25700685

Pune Office / M³ Solution Center

G4/G5, Pride Kumar Senate, Off. Senapati Bapat
Road, Pune-411 016, INDIA

TEL:(91) 20-25660043/44/45 FAX: (91) 20-66033644

Bengaluru Region Head office / M³ Solution Center

No. 5, 100 Ft. Road, 17th Main, Koramangala,
4th Block, Bengaluru-560 034, INDIA
TEL:(91) 80-25630946/47/48 FAX: (91) 80-25630949

Chennai Office / M³ Solution Center

No. 624, Anna Salai Teynampet, Chennai-600 018, INDIA
TEL: (91) 44-24328823/24
FAX: (91) 44-24328825

Kolkata Office

Unit No. 1208,Om Tower, 32,J.L..Nehru Road,
Kolkata-700 071, INDIA
Tel: 91 33-22267088/40060635 Fax: (91) 33-22266817

Ahmedabad Office/M³ Solution Center (Ahmedabad)

A-104 & A-105, First Floor, Solitaire Corporate
Park, Near Divya Bhaskar Press, S.G. Road,
Ahmedabad - 380 015, INDIA
TEL: (91) 079 - 29704902/903

Coimbatore Office

Regus, Srivari Srimath, 3rd Floor, Door No:1045,
Avinashi Road, Coimbatore - 641 018,INDIA
TEL: (91) 9345005663

Taiwan

Mitutoyo Taiwan Co., Ltd. / M³ Solution Center Taipei
4F., No.71, Zhouzi St., Neihu Dist.,Taipei City 114,
TAIWAN (R.O.C.)

TEL:886(2)5573-5900 FAX:886(2)8752-3267

Taichung Branch / M³ Solution Center Taichung

1F., No. 299, Gaotie 1st Rd., Wuri Dist., Taichung
City 414, TAIWAN (R.O.C.)

TEL:886(4)2338-6822 FAX:886(4)2338-6722

Kaohsiung Branch / M³ Solution Center Kaohsiung

1F., No.31-1, Haibian Rd., Lingya Dist.,
Kaohsiung City 802, TAIWAN (R.O.C.)

TEL:886(7)334-6168 FAX:886(7)334-6160

South Korea**Mitutoyo Korea Corporation****Head Office / M³ Solution Center**

(Sanbon-Dong, Geumjeong High View Build.), 6F, 153-8,
Ls-Ro, Gunpo-Si, Gyeonggi-Do, 15808 KOREA

TEL:82(31)361-4200 FAX:82(31)361-4201

Busan Office / M³ Solution Center

(3150-3, Daejeo 2-dong) 8,Yutongdanji 1-ro
49beon-gil, Gangseo-gu, Busan, 46721 KOREA

TEL:82(51)324-0103 FAX:82(51)324-0104

Daegu Office / M³ Solution Center

(Galsan-dong, Daegu Business Center), 301-Ho, 217,
Seongseogongdan-ro, Dalseo-gu, Daegu 42704 KOREA

TEL:82(53)593-5602 FAX:82(53)593-5603

China**Mitutoyo Measuring Instruments (Shanghai) Co., Ltd.**

8th Floor, Tower 1 Lujiazui Jinkong Square
No.1788/1800 Century Ave., Pudong New Dis-
trict, Shanghai 200122, CHINA

TEL:86(21)5836-0718 FAX:86(21)5836-0717

Suzhou Office / M³ Solution Center (Suzhou)

No. 46 Baiyu Road, Suzhou 215021, CHINA

TEL:86(512)6522-1790 FAX:86(512)6251-3420

Wuhan Office / M³ Solution Corner

Room 1701, Wuhan Wanda Center, No. 96,
Linjiang Road, Wuchang District, Wuhan
Hubei 430060, CHINA

TEL:86(27)8544-8631 FAX:86(27)8544-6227

Chengdu Office

1-701, New Angle Plaza, 668# Jindong Road,
Jinjiang District, Chengdu, Sichuan 610066,CHINA

TEL:86(28)8671-8936 FAX:86(28)8671-9086

Hangzhou Office

Room 804, Eastern International Business Cen-
ter Building 1, No.600 Jinsha Road of

Hangzhou Economic and Technological
Development Zone, 310018, CHINA

TEL: 86(571)8288-0319 FAX: 86(571)8288-0320

Tianjin Office / M³ Solution Center China (Tianjin)

Room D 12/F, TEDA Building, No.256 Jie-fang
Nan Road Hexi District,Tianjin 300042, CHINA

TEL:86(22)5888-1700 FAX:86(22)5888-1701

Changchun Office

Room 815, 8F, Building A1, Upper East
International No.3000 Dongsheng Street,
Erdao District, Changchun, Jilin, 130031, CHINA

TEL:86(431)8192-6998 FAX:86(431)8192-6998

Chongqing Office

Room 1312, Building 3, Zhongyu Plaza, No.86,
Hongjin Avenue,Longxi Street, Yubei District,
Chongqing, 400000, CHINA

TEL:86(23)6595-9950 FAX:86(23)6595-9950

Qingdao Office

Room 638, 6F, No.192 Zhengyang Road, Chengyang
District, Qingdao, Shandong, 266109, CHINA

TEL:86(532)8096-1936 FAX:86(532)8096-1937

Xi'an Office

Room 805, Xi'an International Trade Center, No.
196 Xiaozhai East Road, Xi'an, 710061, CHINA

TEL:86(29)8538-1380 FAX:86(29)8538-1381

Dalian Office / M³ Solution Center China (Dalian)

Room A-106 Shuijing SOHO, No.16 Harbin Road, Economic Development Zone, Dalian, 116600 CHINA

TEL:86(411)8718 1212 FAX:86(411)8754-7587

Zhengzhou Office

Room1801,18/F,Unit1,Building No.23, Shangwu Inner Ring Road, Zhengdong New District,Zhengzhou City, Henan 450018, CHINA

TEL:86(371)6097-6436 FAX:86(371)6097-6981

Dongguan Office / M³ Solution Center China (Dongguan)

Room 801, No 65, Chang'an Section Guanchang Road, Chang'an Town, Dongguan City, Guangdong 523841, CHINA

TEL:86(769)8541 7715 FAX:86(769)-8541 7745

Fuzhou Office

Room 2104, City Commercial Centre, No.129 Wu Yi Road N., Fuzhou City, Fujian 350005, CHINA

TEL 86 (591) 8761 8095

FAX 86 (591) 8761 8096

Changsha Office

Room 2207, Building 1, Shiner International Plaza, No. 88, Kaiyuan Middle Road, Changsha City, Hunan 410100, CHINA

TEL 86 (731) 8401 9276

FAX 86 (731) 8401 9376

Mitutoyo Leeport Metrology (Hong Kong) Limited

Room 818, 8/F, Vanta Industrial Centre, No.21-33, Tai Lin Pai Road, Kwai Chung, NT, HONG KONG

TEL:(852)2992-2088 FAX:(852)2670-2488

Mitutoyo Measuring Instruments (Suzhou) Co., Ltd.

No. 46 Baiyu Road, Suzhou 215021, CHINA

TEL:86(512)6252-2660 FAX:86(512)6252-2580

U.S.A.

Mitutoyo America Corporation

965 Corporate Blvd., Aurora, IL 60502, U.S.A.

TEL:1-(630)820-9666 Toll Free No. 1-888-648-8869

FAX:1-(630)978-3501

M³ Solution Center-Illinois

965 Corporate Blvd., Aurora, IL 60502, U.S.A.

M³ Solution Center-Ohio

6220 Hi-Tek Ct., Mason, OH 45040, U.S.A.

TEL:1-(888)-648-8869 FAX:1-(513)754-0718

M³ Solution Center-Michigan

46850 Magellan Drive, Suite 100 Novi, MI 48377, U.S.A.

TEL:1-(888)-648-8869 FAX: 1-(248)-926-0928

M³ Solution Center-California

16925 E. Gale Ave., City of Industry, CA 91745, U.S.A.

TEL:1-(888)-648-8869 FAX:1-(626)369-3352

M³ Solution Center-North Carolina

11515 Vanstory Dr., Suite 140, Huntersville, NC 28078, U.S.A.

TEL:1-(888)-648-8869 FAX:1-(704)875-9273

M³ Solution Center-Alabama

2100 Riverchase Center Suite 106, Birmingham, AL 35244, U.S.A

TEL:1-(888)-648-8869 FAX:1-(205)-988-3423

M³ Solution Center-Washington

1000 SW 34th St. Suite G, Renton, WA 98057 U.S.A.

TEL:1-(888)-648-8869

M³ Solution Center-Texas

4560 Kendrick Plaza Drive Suite 120 Houston, TX 77032, U.S.A.

TEL:1-(888)-648-8869 FAX:1-(281)227-0937

M³ Solution Center-Massachusetts

753 Forest Street, Suite 110, Marlborough, MA 01752, U.S.A.

TEL:1-(888)648-8869 FAX:1-(508)485-0782

Mitutoyo America Corporation Calibration Lab

965 Corporate Blvd., Aurora, IL 60502, U.S.A.

TEL:1-(888)-648-8869 FAX:1-(630)978-6477

Mitutoyo Research & Development America, Inc.

11533 NE 118th St., Kirkland, WA 98034-7111, U.S.A.

TEL:1-(425)821-3906 FAX:1-(425)821-3228

Mitutoyo Research & Development America, Inc. - California Office

16925 Gale Ave. City of Industry, CA 91745-1806 U.S.A.

TEL: 1-(425)821-3906 FAX: 1-(425)821-3228

Mitutoyo America Corporation CT-Lab Chicago

965 Corporate Blvd., Aurora, IL 60502, U.S.A.

TEL: 1-(888)-648-8869 FAX: 1-(630)-820-3418

Canada

Mitutoyo Canada Inc.

2121 Meadowvale Blvd., Mississauga,
Ont. L5N 5N1., CANADA
TEL:1-(905)821-1261 FAX:1-(905)821-4968

Montreal Office

7075 Place Robert-Joncas Suite 129, Montreal,
Quebec H4M 2Z2, CANADA
TEL:1-(514)337-5994 FAX:1-(514)337-4498

Brazil

Mitutoyo Sul Americana Ltda.

Head office / M³ Solution Center

Rodovia Índio Tibiriçá 1555, CEP 08655-000 -
Vila Sol Nascente - Suzano - SP - BRASIL
TEL:55 (11)5643-0040

Argentina

Mitutoyo Sul Americana Ltda.

Argentina Branch / M³ Solution Center

Av. B. Mitre 891/899 – C.P. (B1603CQI)
Vicente López –Pcia. Buenos Aires – ARGENTINA
TEL:54(11)4730-1433 FAX:54(11)4730-1411

Sucursal Cordoba / M³ Solution Center

Av. Amadeo Sabattini, 1296, esq. Madrid B^o
Crisol Sur – CP 5000, Cordoba, ARGENTINA
TEL/FAX:54 (351) 456-6251

Mexico

Mitutoyo Mexicana, S.A. de C.V.

Industria Eléctrica No.15, Parque Industrial, Nau-
calpan de Juárez, Estado de México C.P.53370,
MÉXICO
TEL: 52 (01-55) 5312-5612
FAX: 52 (01-55) 5312-3380

Monterrey Office / M³ Solution Center

Blv. Interamericana No. 103, Parque Industrial
FINSA, C.P. 66636 Apodaca, N.L., MÉXICO
TEL: 52(01-81) 8398-8227/8228/8242/8244
FAX: 52(01-81) 8398-8226

Tijuana Office / M³ Solution Center

Calle José María Velazco 10501-C, Col. Cd. Industrial
Nueva Tijuana, C.P. 22500 Tijuana, B.C., MÉXICO
TEL: 52 (01-664) 647-5024

Querétaro Office / M³ Solution Center

Av. Cerro Blanco No.500-1, Colonia Centro Sur,
Querétaro, Querétaro, C.P. 76090, MÉXICO
TEL: 52 (01-442) 340-8018, 340-8019 and 340-8020
FAX: 52 (01-442) 340-8017

Mitutoyo Mexicana, S.A. de C.V. Querétaro Calibration Laboratory

Av. Cerro Blanco 500 30 Centro Sur,
Querétaro, Querétaro, C.P. 76090, MÉXICO
TEL: 52 (01-442) 340-8018, 340-8019 and 340-8020
FAX: 52 (01-442) 340-8017

Aguascalientes Office / M³ Solution Center

Av. Aguascalientes No. 622, Local 15 Centro Comer-
cial El Cilindro Fracc. Pulgas Pandas Norte, C.P.
20138, Aguascalientes, Ags. MÉXICO
TEL: 52 (01-449) 174-4140 and 174-4143

Irapuato Office / M³ Solution Center

Boulevard a Villas de Irapuato No. 1460 L.1 Col. Ejido
Irapuato C.P. 36643
Irapuato, Gto., MÉXICO
TEL: 52 (01-462) 144-1200 and 144-1400

Revision Record

Date of publication	Revision status	Details of revision
November 1, 2018	First edition	Publication
August 1, 2021	Revision first edition	Revision according to increase/decrease of model and due to changes of the harmonized European standards & Additions and changes due to application of the UKCA (UK Conformity Assessed) marking, etc.

Mitutoyo Corporation

20-1, Sakado 1-Chome, Takatsu-ku, Kawasaki-shi, Kanagawa 213-8533, Japan
Tel: +81 (0)44 813-8230 Fax: +81 (0)44 813-8231
Home page: <https://www.mitutoyo.co.jp/global.html>

For the EU Directive, Authorized representative and importer in the EU:
Mitutoyo Europe GmbH
Borsigstrasse 8-10, 41469 Neuss, Germany

For the UK Regulation, Authorized representative and importer in the UK:
Mitutoyo (UK) Ltd.
Joule Road, West Point Business Park, Andover, Hampshire SP10 3UX, UNITED KINGDOM